Photo-electric sensors

XU range

Material handling & working, packaging

Catalogue



Photo-electric sensors

XU range

Selection guidepage 2

XU range, general purpose

- XUM, miniature design, plastic
 - Thru-beam system with adjustable sensitivity page 8
 - Polarised reflex system with adjustable sensitivity page 9
 - Background suppression system with adjustable sensitivity page 9
 - Diffuse system with adjustable sensitivity page 10
 - Accessories for all XUM miniature sensors page 11
 - Characteristics page 12
 - Schemes page 13
 - Curves page 14
 - Description, dimensions – Systems page 18
 - Dimensions – Accessories page 19
- XUB, cylindrical miniature design 18, plastic or metal
 - Thru-beam system with adjustable sensitivity, plastic page 20
 - Thru-beam system with adjustable sensitivity, metal page 21
 - Diffuse system with adjustable sensitivity, plastic page 22
 - Diffuse system with adjustable sensitivity, metal page 23
 - Polarised reflex system with adjustable sensitivity, plastic page 24
 - Polarised reflex system with adjustable sensitivity, metal page 25
 - Characteristics page 26
 - Schemes page 27
 - Curves page 29
 - Dimensions page 34
- XUN, hybrid miniature design, plastic
 - Thru-beam system with adjustable sensitivity page 40
 - Diffuse system with adjustable sensitivity page 41
 - Polarised reflex system with adjustable sensitivity page 42
 - Characteristics page 43
 - Schemes page 44
 - Curves page 46
 - Dimensions page 49

XU range application

- General presentation page 52
- XU range application, contrast system for marking detection
 - Contrast mark reader sensors, white light page 54
 - Contrast mark reader sensors, RGB light page 54
 - Contrast mark reader sensors, laser light page 54
 - Characteristics page 55
 - Schemes page 56
 - Curves page 57
 - Dimensions page 57
- XU range application, blue light sensors for very dark object detection
 - Adjustable blue light sensors page 58
 - Fixed blue light sensors, miniature page 58
 - Fixed blue light sensors, sub-miniature page 58
 - Adjustable blue light sensors (potentiometer) page 58
 - Characteristics page 59
 - Schemes page 60
 - Curves page 62
 - Dimensions page 63

■ XU range application, laser sensors for accurate detection	
□ Lasers sensors, diffuse mode detection	page 64
□ Lasers sensors, BGS mode detection	page 64
□ Lasers sensors, reflex mode detection	page 64
□ Characteristics	page 65
□ Schemes	page 66
□ Dimensions	page 67
□ Curves	page 68
■ XU range application, sensors for colour detection	
□ Colour sensors, white light, multiple colour	page 70
□ Colour sensors, RGB light, unique colour	page 70
□ Characteristics	page 70
□ Schemes	page 71
□ Curves	page 71
□ Dimensions	page 71
■ XU range application, sensors for transparent object detection	
□ Polarised reflex system	page 72
□ BGS mode detection, adjustable	page 72
□ BGS mode detection, not adjustable	page 72
□ BGS mode detection, compact	page 72
□ Characteristics	page 73
□ Schemes	page 74
□ Dimensions	page 75
□ Curves	page 76

XU range accessories

■ IO-Link Master	page 78
■ Fixing brackets	page 82
■ Mounting rings	page 82
■ Reflectors	page 86
■ Cabling accessories	page 88
□ Pre-wired connectors, references	page 88
□ Jumper cables, references	page 89
□ Pre-wired connectors M8 and M12, characteristics	page 90
□ Shielded cables with pre-wired connectors M12, characteristics	page 92
□ Jumper cables M12-M12, characteristics	page 94
□ Shielded jumper cables M12-M12, characteristics	page 95
□ Jumper cables M8-M8 and M8-M12, characteristics	page 96

Index

■ Product reference index	page 98
---------------------------	---------

Photo-electric sensors

XU range General purpose

Single mode function

Format

Design 18, cylindrical miniature



Dimensions (Ø or w x h x d) in mm		
Case (material)	Plastic	PBT/PC ABS
	Metal	Nickel plated brass Stainless steel
Sensing distance Sn (m) related to system	Thru-beam	XU●2
	Diffuse short distance	XU●4
	Diffuse long distance	XU●5
	Diffuse medium distance	XU●6
	Background suppression	XU●8
	Polarised reflex	XU●9
LED emission		
Degree of protection		
Supply	≡ 3-wire (PNP/NPN)	
	≡ 4-wire (PNP/NPN)	
	≈ 5-wire, relay output	
Function		NO
		NC
		NO/NC
		NO + NC
Connection	Pre-cabled	(L = 2 m)
	Connector	M8 (4-pin) ≡ 3-wire M12 (4-pin) ≡ 4-wire
	Pigtail	0.3 m
Type reference		
Pages		

Ø 18, threaded M18 x 1 Length: 44		Ø 18, threaded M18 x 1 Length: 55.2		Ø 18, threaded M18 x 1 Length: 44		Ø 18, threaded M18 x 1 Length: 55.2	
✓				–			
–				–			
–				✓			
–				–			
<i>For straight light axis</i>		<i>For angled light axis</i>		<i>For straight light axis</i>		<i>For angled light axis</i>	
30		17		30		17	
–							
1		–		1		–	
0.6		0.5		0.6		0.5	
–							
7		5.5		7		5.5	
Red light							
All: IP65, IP67 M12 connector only: IP69K							
–				–			
✓				✓			
–				–			
–				–			
✓		✓		✓		✓	
–		–		–		–	
✓		✓		✓		✓	
–				–			
✓		✓		✓		✓	

XUB
20

Miniature design	Hybrid miniature design
Plastic	Plastic



19.5 x 31.5 x 10.8		15 x 59.2 x 31.9	
✓		-	
-		✓	
-		-	
-		-	
With excess gain = 1	With excess gain = 2	With excess gain = 1	With excess gain = 2
30	24	30	20
0.25	0.17	-	
1.9	1.5	1	0.7
1.1	0.8	0.6	0.42
4...300: White paper or object. Sn (90%) 5...265: Grey object. Sn (18%) 8...200: Black object. Sn (6%)		-	
0.05...8	0.05...6.7	7	5
Red light for: XUM2, XUM6, XUM8, XUM9 Infrared light for: XUM4, XUM 5		Red light	
All: IP65, IP67		All: IP65, IP67 M12 connector only: IP69K	
✓		-	
-		✓	
-		-	
-		-	
-		-	
✓		✓	
-		-	
✓		✓	
✓		-	
-		✓	
✓		-	
XUM	XUN		
8	40		

Recommended applications

Material handling, Material working, Packaging

Marking detection



Format	
Dimensions (w x h x d) in mm	
Case (material)	Plastic
	PBT/PC
	ABS
	ABS/PC
	PUR
Metal	Glass-filled technopolymer
	Nickel plated brass
	Stainless steel
	Zinc die-cast
Technology	
Sensing distance (Sn)	XUKC
	XUMR
	XUMT
	Thru-beam XU●2
	Diffuse short distance XU●4
	Diffuse medium distance XU●5
	Diffuse long distance XU●6
	Background suppression fixed XU●7
	Background suppression adjust. XU●8
Polarised reflex XU●9	
LED emission	
Degree of protection	IP67
	IP69K
Supply	---
	~
	⌚
Output	Autodetect PNP/NPN
	PNP
	NPN
Connection	Pre-cabled
	L=2 m
	Connector
	M8
	M12
Pigtail	L=0.15 m (M12)
	L=0.2 m (M8)
Type reference	
Pages	

Miniature			
12 x 34 x 20		10.8 x 31.5 x 19.5	
-	-	-	-
✓	✓	✓	-
-	-	-	-
-	-	-	-
-	-	-	✓
-	-	-	-
-	-	-	-
-	-	-	-
-	-	-	-
Contrast			
-	-	-	-
12 mm	12 mm	-	12 mm
-	-	-	-
-	-	-	-
-	-	150 mm	-
-	-	-	-
-	-	-	-
-	-	-	-
-	-	-	-
White light	RGB light	Laser light	RGB light
✓	✓	✓	✓
✓	✓	✓	-
12...24V			
-	-	-	-
-	-	-	-
✓	✓	✓	✓
-	-	-	-
-	-	-	-
-	-	✓	-
✓	✓	✓	✓
-	-	-	-
✓	✓	✓	-
-	-	-	-
XUMRAWAY●●	XUMRAGAY●● XUMRACAY●● XUMRPGAYM8	XUM5ALAY●●	XUMRPGAYM8
54			

(1) Depending on fibres used.
 (2) Depending on model.

Material handling, Material working, Packaging

Very dark object detection



Compact	Miniature	Sub-miniature
23 x 50 x 50	12 x 34 x 20	8 x 21.1 x 14.6
-	-	-
✓	✓	-
-	-	-
-	-	✓
-	-	-
-	-	-
-	-	-
-	-	-
BGS		
-	-	-
-	-	-
-	-	-
-	-	-
-	-	-
-	-	-
-	-	-
-	80 mm	50 mm
1200 mm	200 mm	100 mm
-	-	-
Blue light		
✓	✓	✓
✓	✓	-
12...24V	12...24V	12...24V for XUT7 24V for XUT8
-	-	-
-	-	-
-	XUM8ABAY●●	XUT8ABAY●●
✓	XUM7ABPX●●	XUT7ABPX●●
-	-	-
-	XUM7ABPX●●	✓
-	✓	-
✓	-	-
-	XUM8ABAY●●	-
-	-	✓
XUK8ABPX●●	XUM7ABPX●● XUM8ABAY●●	XUT7ABPX●● XUT8ABAY●●

Recommended applications

Material handling, Material working, Packaging

Accurate detection



Format		
Dimensions (w x h x d) in mm		
Case (material)	Plastic	
	PBT/PC	
	ABS	
	ABS/PC	
	PUR	
Metal	Glass-filled technopolymer	
	Nickel plated brass	
	Stainless steel	
Zinc die-cast		
Technology		
Sensing distance (Sn)	XUKC	
	XUMR	
	XUMT	
	Thru-beam	XU●2
	Diffuse short distance	XU●4
	Diffuse medium distance	XU●5
	Diffuse long distance	XU●6
	Background suppression fixed	XU●7
	Background suppression adjust.	XU●8
Polarised reflex	XU●9	
LED emission		
Degree of protection	IP65	
	IP67	
	IP69K	
Supply	☐	
	~	
	⌚	
Output	Autodetect PNP/NPN	
	PNP	
	NPN	
Connection	Pre-cabled	
	L=2 m	
	Connector	
	M8	
	M12	
Pigtail	L=0.15 m (M12)	
	L=0.2 m (M8)	
Type reference		
Pages		

Miniature		Sub-miniature	
12 x 34 x 20	10.8 x 31.5 x 19.5	8 x 21.1 x 14.6	
-	-	-	-
✓	-	-	-
-	-	-	-
-	-	-	✓
-	✓	✓	-
-	-	-	-
-	-	-	-
-	-	-	-
Diffuse, BGS, reflex	BGS	Reflex	BGS, reflex
-	-	-	-
-	-	-	-
-	-	-	-
250 mm	-	-	-
-	-	-	-
-	-	-	-
150 mm	200	200	100 mm
15 m	-	-	4 m
Laser light			
-	✓	✓	-
✓	✓	✓	✓
✓	-	-	-
12...24V	10...30V	12...24V	
-	-	-	-
-	-	-	-
✓	-	-	XUT8ALAYL2
-	✓	✓	XUT9ALPX●●
-	-	-	-
✓	-	-	✓
✓	✓	-	-
-	-	-	-
✓	-	-	-
-	-	-	✓
XUM5ALAY●● XUM8ALAY●● XUM9ALAY●● XUM●PLPX8	XUM8PLPX8	XUM9PLPX8	XUT8ALAY●● XUT9ALPX●●
64			

Material handling, Material working, Packaging

Color object detection

Transparent object detection



Compact	Miniature	Compact	Miniature	10.8 x 31.5 x 19.5	Sub-miniature
3 x 50 x 250	8 x 21.1 x 14.6	23 x 50 x 50	12 x 34 x 20	10.8 x 31.5 x 19.5	8 x 21.1 x 14.6
-	-	-	-	-	-
-	✓	-	✓	-	-
-	-	✓	-	-	-
-	-	-	-	-	✓
-	-	-	-	✓	-
-	-	-	-	-	-
-	-	-	-	-	-
✓	-	-	-	-	-
Color mode		BGS	Reflex (polarized, transparent, BGS)	Transparent reflex	BGS
60 mm XUKCBSAY 150 mm XUKCBLAY	✓	-	-	-	-
-	12 mm	-	-	-	-
-	-	-	2 m	-	-
-	-	-	-	-	-
-	-	-	-	-	-
-	-	-	-	-	-
-	-	-	100 mm	-	50 mm
-	-	1200 mm	200 mm	-	100 mm
-	-	-	-	-	-
White light	RGB light	Blue light	Red light for XUMTA Blue light for XUM7 and XUM8	Red light	Blue light
-	-	-	-	-	-
✓	✓	✓	✓	✓	✓
✓	✓	✓	✓	-	✓ (only XUT8)
24V	12...24V	12...24V	24V for XUMTA 12...24V for XUM8 and XUM7	10...30V	24V
-	-	-	-	-	-
-	-	-	-	-	-
-	✓	-	XUM8ABAY●● XUM7ARAY●●	-	XUT8ABAY●●
-	-	✓	XUM7ABPX●●	✓	XUT7ABPX●●
-	-	-	-	-	-
-	-	-	XUM7ARAY●● XUM7ABPX●●	-	XUT7ABPX●● XUT8ABAY●●
-	✓	-	XUM7ARAY●● XUM7ABPX●● XUM8ABAY●●	✓	-
✓	-	✓	-	-	-
-	✓	-	XUM7ARAY●● XUM8ABAY●●	-	-
-	-	-	-	-	XUT7ABPX●● XUT8ABAY●●
XUKCB●AYM12	XUMRACAYM8	XUK8ABPXM12	XUM7ARAY●● XUM8ABAY●● XUM7ABPX●● XUM7PRXM8	XUM7PRXM8	XUT7ABPX●● XUT8ABAY●●

70

72

Photo-electric sensors

XUM, general purpose, single mode function

Miniature design, plastic

Three-wire DC, solid-state output



XUM2A●XBL2,
XUM2A●XBL03M8,
XUM2A●XBL03M12



XUM2A●XBM8

Thru-beam system with adjustable sensitivity								
Max./operating sensing distance (Sn)	Function	Output	Connection	Reference	Weight (kg)			
Transmitter + receiver IO-Link								
30 m/24 m	NC/NO (Light ON/Dark ON) configuration by IO-Link and potentiometer	Autodetect PNP/NPN	M8 connector (4-pin)	XUM2APYBM8 (1)	0.010			
			Pigtail M12 (4-pin)	XUM2APYBL03M12 (1)	-			
Transmitter + receiver								
30 m/24 m	NC/NO (Light ON/Dark ON) configuration by potentiometer	PNP	Pre-cabled (L = 2 m)	XUM2APXBL2	0.096			
			M8 connector (4-pin)	XUM2APXBM8	0.026			
			Pigtail M8 (4-pin)	XUM2APXBL03M8 (1)	-			
			Pigtail M12 (4-pin)	XUM2APXBL03M12 (1)	-			
			NPN	Pre-cabled (L = 2 m)	XUM2ANXBL2	0.096		
		M8 connector (4-pin)	XUM2ANXBM8	0.026				
		Pigtail M8 (4-pin)	XUM2ANXBL03M8 (1)	-				
		Pigtail M12 (4-pin)	XUM2ANXBL03M12 (1)	-				
		Transmitter only						
		30 m/24 m			Pre-cabled (L = 2 m)	XUM2AKXBL2T	0.063	
M8 connector (4-pin)	XUM2AKXBM8T				0.010			
Pigtail M8 (4-pin)	XUM2AKXBL03M8T (1)				-			
Pigtail M12 (4-pin)	XUM2AKXBL03M12T (1)				-			
Receiver only IO-Link								
30 m/24 m	NC/NO (Light ON/Dark ON) configuration by IO-Link and potentiometer	Autodetect PNP/NPN	M8 connector (4-pin)	XUM2APYBM8R (1)	0.010			
			Pigtail M12 (4-pin)	XUM2APYBL03M12R (1)	-			
Receiver only								
30 m/24 m	NC/NO (Light ON/Dark ON) configuration by potentiometer	PNP	Pre-cabled (L = 2 m)	XUM2APXBL2R	0.063			
			M8 connector (4-pin)	XUM2APXBM8R	0.010			
			Pigtail M8 (4-pin)	XUM2APXBL03M8R (1)	-			
			M12 connector (4-pin)	XUM2APXBL03M12R (1)	-			
			NPN	Pre-cabled (L = 2 m)	XUM2ANXBL2R	0.063		
		M8 connector (4-pin)	XUM2ANXBM8R	0.010				
		Pigtail M8 (4-pin)	XUM2ANXBL03M8R (1)	-				
		Pigtail M12 (4-pin)	XUM2ANXBL03M12R (1)	-				

Accessories

For all XUM miniature sensors

See page 11.

For thru-beam system

See page 11.

IO-Link Master

See page 78.

Fixing and other accessories

See page 82.

Cabling accessories

See page 88.

(1) Available 3rd quarter 2025.

Photo-electric sensors

XUM, general purpose, single mode function

Miniature design, plastic

Three-wire DC, solid-state output

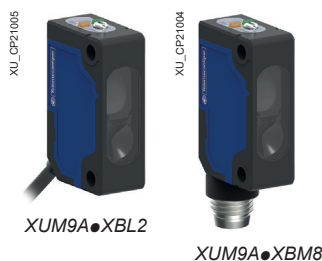

Polarised reflex system with adjustable sensitivity

Max./operating sensing distance (Sn)	Function	Output	Connection	Reference	Weight (kg)	
Sensors IO-Link						
8 m/6.7 m with reflector XUZC50	NC/NO (Light ON/Dark ON) configuration by IO-Link and potentiometer	Autodetect PNP/NPN	M8 connector (4-pin)	XUM9APYBM8 (1)	0.010	
			Pigtail M12 (4-pin)	XUM9APYBL03M12 (1)	–	
Standard sensors						
8 m/6.7 m with reflector XUZC50	NC/NO (Light ON/Dark ON) configuration by potentiometer	PNP	Pre-cabled (L = 2 m)	XUM9APXBL2	0.063	
			M8 connector (4-pin)	XUM9APXBM8	0.010	
			Pigtail M8 (4-pin)	XUM9APXBL03M8 (1)	–	
			Pigtail M12 (4-pin)	XUM9APXBL03M12 (1)	–	
			NPN	Pre-cabled (L = 2 m)	XUM9ANXBL2	0.063
				M8 connector (4-pin)	XUM9ANXBM8	0.010
		Pigtail M8 (4-pin)		XUM9ANXBL03M8 (1)	–	
		Pigtail M12 (4-pin)		XUM9ANXBL03M12 (1)	–	



Background suppression system with adjustable sensitivity

Max./operating sensing distance (Sn)	Function	Output	Connection	Reference	Weight (kg)
300 mm/200 mm (white object or paper)	NO/NC (Light ON/Dark ON) configuration by potentiometer	PNP	Pre-cabled (L = 2 m)	XUM8APXBL2	0.063
			M8 connector (4-pin)	XUM8APXBM8	0.010
			NPN	Pre-cabled (L = 2 m)	XUM8ANXBL2
		M8 connector (4-pin)		XUM8ANXBM8	0.010

Accessories

For all XUM miniature sensors

See page 11.

IO-Link Master

See page 78.

Fixing and other accessories

See page 82.

Cabling accessories

See page 88.

(1) Available 3rd quarter 2025.

Photo-electric sensors

XUM, general purpose, single mode function

Miniature design, plastic

Three-wire DC, solid-state output



Diffuse system with adjustable sensitivity						
Max./operating sensing distance (Sn)	Function	Output	Connection	Reference	Weight (kg)	
Diffuse short range						
0.25 m/0.17 m	NO/NC (Light ON/Dark ON) configuration by potentiometer	PNP	Pre-cabled (L = 2 m)	XUM4APXBL2	0.063	
			M8 connector (4-pin)	XUM4APXBM8	0.010	
			Pigtail M8 (4-pin)	XUM4APXBL03M8 (1)	-	
			Pigtail M12 (4-pin)	XUM4APXBL03M12 (1)	-	
	NPN	Pre-cabled (L = 2 m)	XUM4ANXBL2	0.063		
		M8 connector (4-pin)	XUM4ANXBM8	0.010		
		Pigtail M8 (4-pin)	XUM4ANXBL03M8 (1)	-		
		Pigtail M12 (4-pin)	XUM4ANXBL03M12 (1)	-		



Diffuse medium range IO-Link						
1.1 m/0.8 m	NO/NC (Light ON/Dark ON) configuration by IO-Link and potentiometer	Autodetect PNP/NPN	M8 connector (4-pin)	XUM6APYBM8 (1)	-	
			Pigtail M12 (4-pin)	XUM6APYBL03M12 (1)	-	
Diffuse medium range						
1.1 m/0.8 m	NO/NC (Light ON/Dark ON) configuration by potentiometer	PNP	Pre-cabled (L = 2 m)	XUM6APXBL2	0.063	
			M8 connector (4-pin)	XUM6APXBM8	0.010	
			Pigtail M8 (4-pin)	XUM6APXBL03M8 (1)	-	
			Pigtail M12 (4-pin)	XUM6APXBL03M12 (1)	-	
	NPN	Pre-cabled (L = 2 m)	XUM6ANXBL2	0.063		
		M8 connector (4-pin)	XUM6ANXBM8	0.010		
		Pigtail M8 (4-pin)	XUM6ANXBL03M8 (1)	-		
		Pigtail M12 (4-pin)	XUM6ANXBL03M12 (1)	-		



Diffuse long range IO-Link						
1.9 m/1.5 m	NO/NC (Light ON/Dark ON) configuration by IO-Link and potentiometer	Autodetect PNP/NPN	M8 connector (4-pin)	XUM5APYBM8 (1)	-	
			Pigtail M12 (4-pin)	XUM5APYBL03M12 (1)	-	
Diffuse long range						
1.9 m/1.5 m	NO/NC (Light ON/Dark ON) configuration by potentiometer	PNP	Pre-cabled (L = 2 m)	XUM5APXBL2	0.063	
			M8 connector (4-pin)	XUM5APXBM8	0.010	
			Pigtail M8 (4-pin)	XUM5ANXBL03M8 (1)	-	
			M12 connector (4-pin)	XUM5ANXBL03M12 (1)	-	
	NPN	Pre-cabled (L = 2 m)	XUM5ANXBL2	0.063		
		M8 connector (4-pin)	XUM5ANXBM8	0.010		
		Pigtail M8 (4-pin)	XUM5ANXBL03M8 (1)	-		
		Pigtail M12 (4-pin)	XUM5ANXBL03M12 (1)	-		

Accessories for XU sensors

For all XUM miniature sensors

See page 11.

IO-Link Master

See page 78.

Fixing and other accessories

See page 82.

Cabling accessories

See pages 88 to 93.

(1) Available 3rd quarter 2025.



XUZASM05

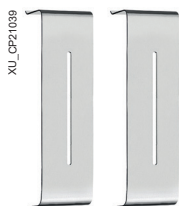

XUZDVM●●

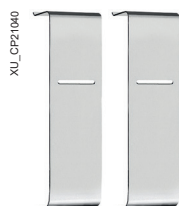

XUZDHM●●



XUZDRM●●

Accessories for all XUM miniature sensors

Setting-up accessory

Description	For use with sensors	Reference	Weight (kg)
Air blower mounting block (1) for cleaning the sensitive face of the sensor, using compressed air.	XUM●A●XBL2 XUM●A●XBM8	XUZASM05	0.030
Supplied with 2 mounting screws (M3 x 20), 1 air supply port plugging screw for the unused port (of 2 available) and 1 gasket.			

Accessories for thru-beam system

Diaphragms

Description	Dimensions (mm)	Sensing distance (m)	Reference	Weight (kg)
Vertical diaphragm Sold in lots of 2	0.5 x 6.4	1	XUZDVM05	0.003
	1 x 6.4	1.5	XUZDVM10	0.003
	2 x 6.4	3.5	XUZDVM20	0.003
Horizontal diaphragm Sold in lots of 2	0.5 x 6.4	0.7	XUZDHM05	0.003
	1 x 6.4	1.5	XUZDHM10	0.003
	2 x 6.4	3	XUZDHM20	0.003
Round diaphragm Sold in lots of 2	0.5 x 6.4	0.08	XUZDRM05	0.003
	1 x 6.4	0.3	XUZDRM10	0.003
	2 x 6.4	1.2	XUZDRM20	0.003

Accessories for XU sensors

IO-Link Master

See page 78.

Fixing and other accessories

See page 82.

Cabling accessories

See pages 88 to 93.

(1) To order these references, please contact our Customer Care Centre.

Photo-electric sensors

XUM, general purpose, single mode function

Miniature design, plastic

Three-wire DC, solid-state output

Characteristics				XUM●A●●BM8	XUM●A●●BL03M●	XUM●A●XBL2
Sensor type						
Product certifications				CE, UKCA, cULus EAC, RCM (<i>pending</i>)		
Connection	Connector		M8	–	–	–
	Pigtail		–	Length: 0.3 m	–	–
	Pre-cabled		–	–	–	Length: 2 m
Configuration				IO-Link Potentiometer	IO-Link Potentiometer	Potentiometer
Nominal sensing distance Sn	Thru-beam system	XUM2	m	30 (with excess gain = 1) 24 (with excess gain = 2)		
	Polarised reflex system (using a 50 x 50 mm reflector XUZC50)	XUM9	m	0.05...8 (with excess gain = 1) 0.05...6.7 (with excess gain = 2)		
	Background suppression system	XUM8	mm	4...300: White paper or object. Sn (90%) 5...265: Grey object. Sn (18%) 8...200: Black object. Sn (6%)		
	Diffuse system (using a white paper 200 x 200 mm)	XUM4	m	0.25 (with excess gain = 1) 0.17 (with excess gain = 2)		
		XUM5	m	1.9 (with excess gain = 1) 1.5 (with excess gain = 2)		
		XUM6	m	1.1 (with excess gain = 1) 0.8 (with excess gain = 2)		
Hysteresis				2% < H < 20% at Sn		
Type of transmission	Red	XUM2		Thru-beam system		
		XUM6		Diffuse system		
		XUM8		Background suppression system		
		XUM9		Polarised reflex system		
	Infrared	XUM4		Diffuse system		
		XUM5		Diffuse system		
Degree of protection				Conforming to IEC 60529		
Storage temperature				°C -40...+70		
Operating temperature				°C -30...+55		
Materials	Case		PBT			
	Lens		PMMA			
	Display		PC			
	Cable		–	PVC	PVC	PVC
Vibration resistance				Conforming to IEC 60068-2-6		
Shock resistance				Conforming to IEC 60068-2-27		
Indicator lights				Output state		
				Yellow LED		
				Stability		
				Green LED (XUM4, XUM5, XUM6, XUM8, XUM9)		
				Power on		
				Green LED (XUM2)		
Rated supply voltage				V 12...24 ̄ with protection against reverse polarity		
Voltage limits (including ripple)				V 10...30 ̄		
Current consumption, no-load				mA < 20 max.		
Switching capacity				mA 100		
Voltage drop, closed state				V ≤ 2		
Maximum switching frequency				Hz 1000		
Delays	First-up		ms	< 100		
	Response		ms	0.5		
	Recovery		ms	0.5		
	IO-Link		ms	< 300		

Photo-electric sensors

XUM, general purpose, single mode function

Miniature design, plastic

Three-wire DC, solid-state output

Wiring schemes

Thru-beam system

M8 and M12 connectors - 4-pin IO-Link

Pin	Signal	Definition
1	+	+ 24 V $\overline{\text{DC}}$
2	IN	+ = NO - = NC Open = NO
3	-	0 V $\overline{\text{DC}}$
4	Q	Switching signal (SIO)
	C	IO-Link communication

Autodetect PNP/NPN or by IO-Link

XUM2APYBM8, XUM2APYBM8R, XUM2APYBL03M12, XUM2APYBL03M12R

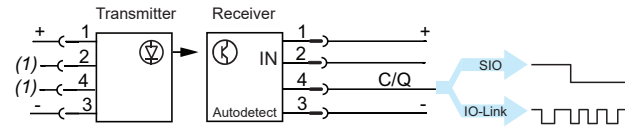

M8 and M12 connectors - 4-pin

Pin	Signal	Definition
3	-	
1	+	
4	OUT/Output	

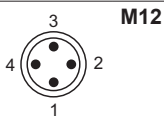

PNP

XUM2APXBM8, XUM2APXBL03M8, XUM2AKXBM8T, XUM2AKXBL03M8T, XUM2APXBM8R, XUM2APXBL03M8R, XUM2APXBL03M12, XUM2AKXBL03M12T, XUM2APXBL03M12R

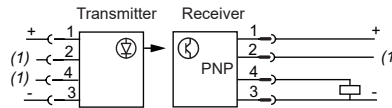

NPN

XUM2ANXBM8, XUM2ANXBL03M8, XUM2ANXBM8R, XUM2ANXBL03M8R, XUM2ANXBL03M12, XUM2ANXBL03M12R

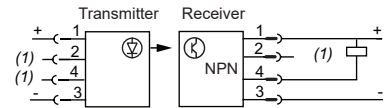

Pre-cabled - 3-wire

(-) BU (Blue)
(+) BN (Brown)
OUT/Output BK (Black)

PNP

XUM2APXBL2, XUM2AKXBL2T, XUM2APXBL2R

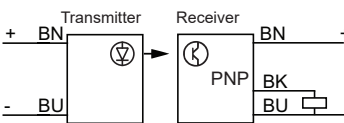

NPN

XUM2ANXBL2, XUM2ANXBL2R

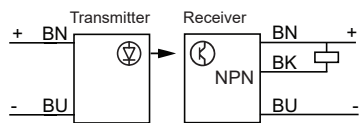

Polarised reflex, background suppression and diffuse systems

M8 and M12 connectors - 4-pin IO-Link

Pin	Signal	Definition
1	+	+ 24 V $\overline{\text{DC}}$
2	IN	+ = NO - = NC Open = NO
3	-	0 V $\overline{\text{DC}}$
4	Q	Switching signal (SIO)
	C	IO-Link communication

XUM●APYBL03M12, XUM●APYBM8

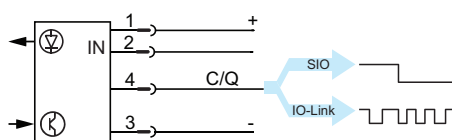

M8 and M12 connectors- 4-pin

Pin	Signal	Definition
1	+	+ 24 V $\overline{\text{DC}}$
2	IN	+ = NO - = NC Open = NO
3	-	0 V $\overline{\text{DC}}$
4	Q	Switching signal (SIO)

PNP

XUM●APXBL03M12, XUM●APXBM8, XUM●APXBL03M8

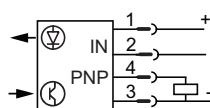

NPN

XUM●ANXBL03M12

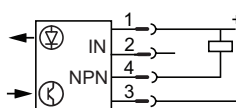

Pre-cabled - 3-wire

(-) BU (Blue)
(+) BN (Brown)
OUT/Output BK (Black)

PNP

XUM●APXBL2

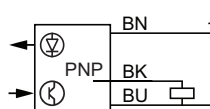

NPN

XUM●ANXBL2

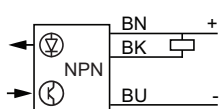

(1) Not connected.

Photo-electric sensors

XUM, general purpose, single mode function

Miniature design, plastic

Three-wire DC, solid-state output

Detection curves

Thru-beam system: XUM2

Lateral displacement

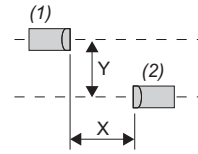
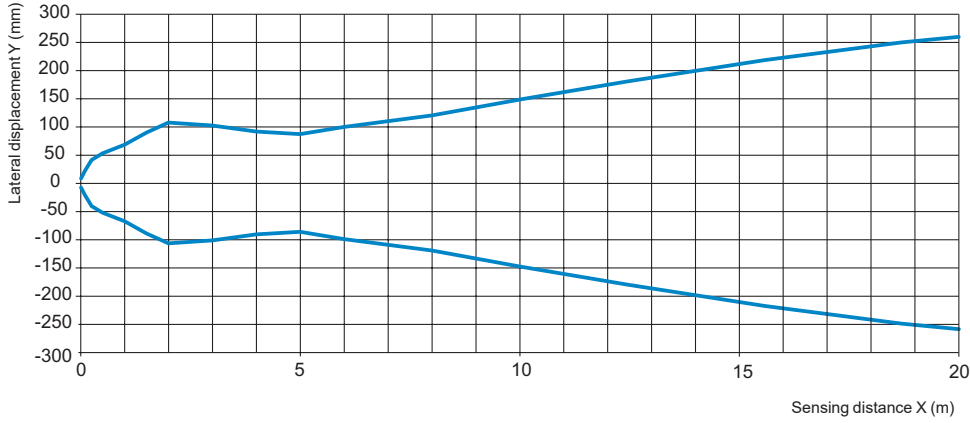

(1): Transmitter
(2): Receiver

Light beam diameter

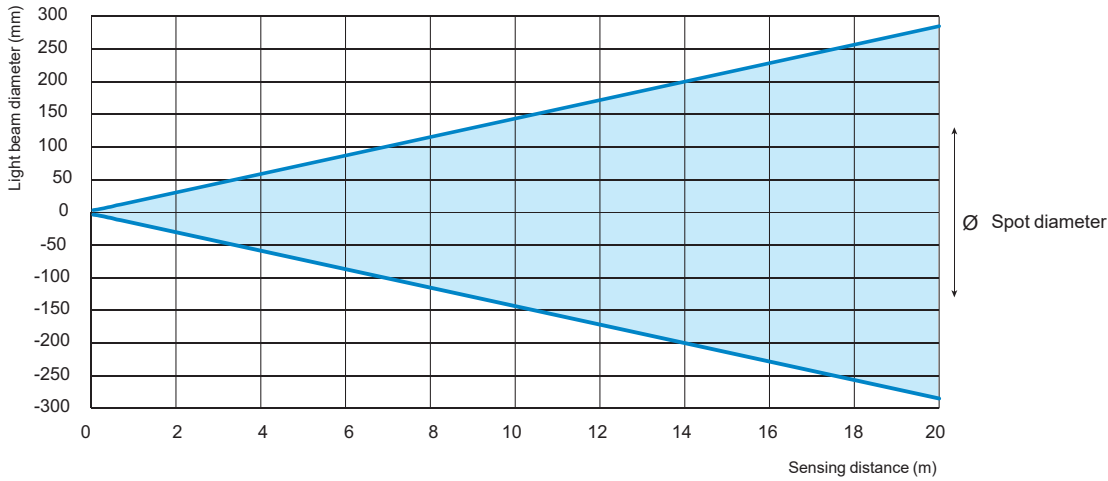

Excess gain

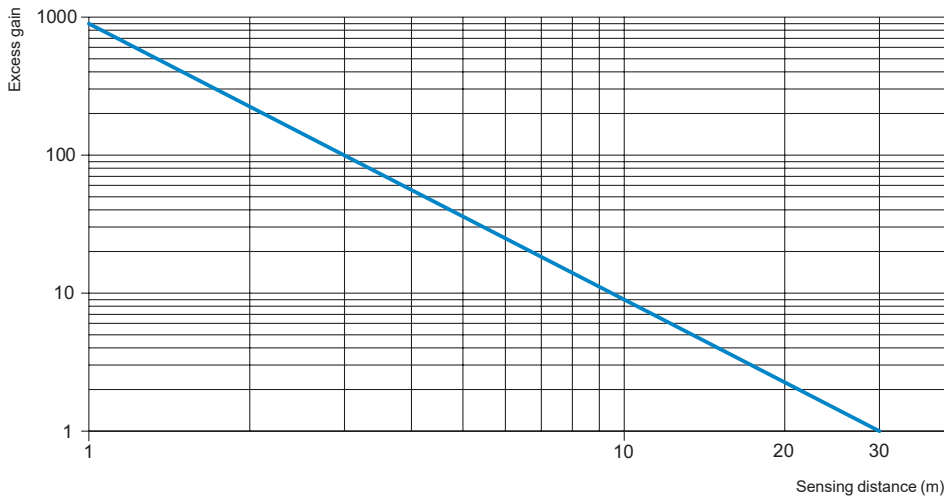

Photo-electric sensors

XUM, general purpose, single mode function

Miniature design, plastic

Three-wire DC, solid-state output

Detection curves

Polarised reflex system: XUM9

Reflector angle

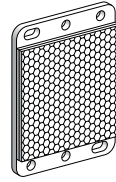
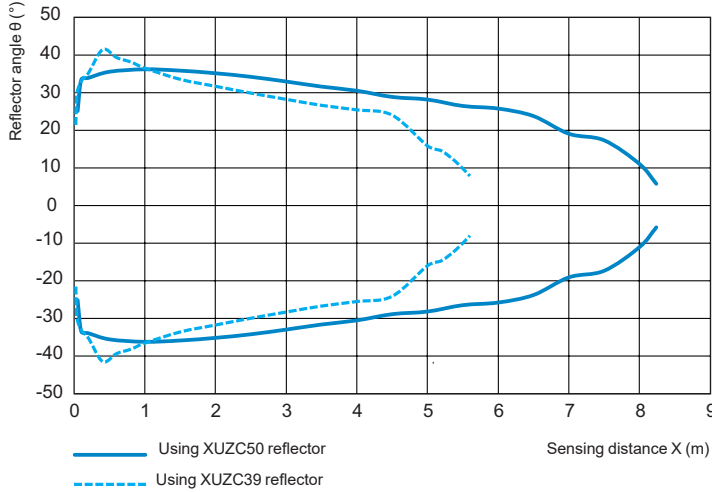

XUZC50



XUZC39

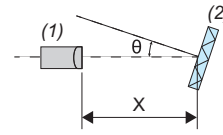

(1): Sensor
(2): Reflector
 θ : Reflector angle (°)
X: Sensing distance (m)

Lateral displacement

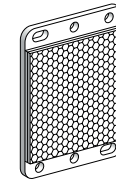
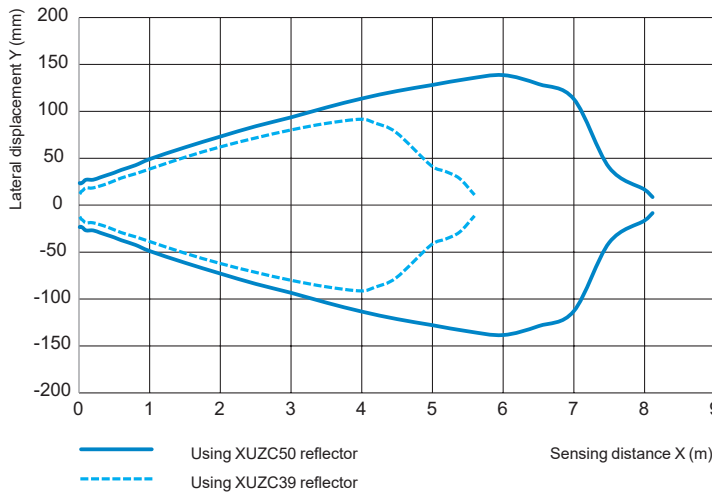

XUZC50



XUZC39

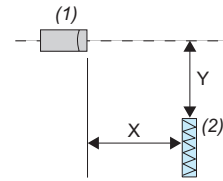

(1): Sensor
(2): Reflector
Y: Lateral displacement (mm)
X: Sensing distance (m)

Excess gain

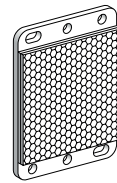
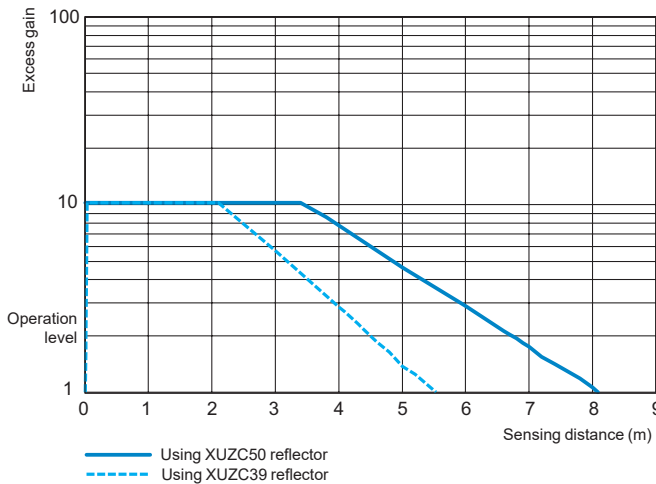

XUZC50



XUZC39

Photo-electric sensors

XUM, general purpose, single mode function

Miniature design, plastic

Three-wire DC, solid-state output

Detection curves (continued)

Background suppression system: XUM8

Lateral displacement (preset 100 mm)

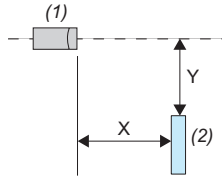
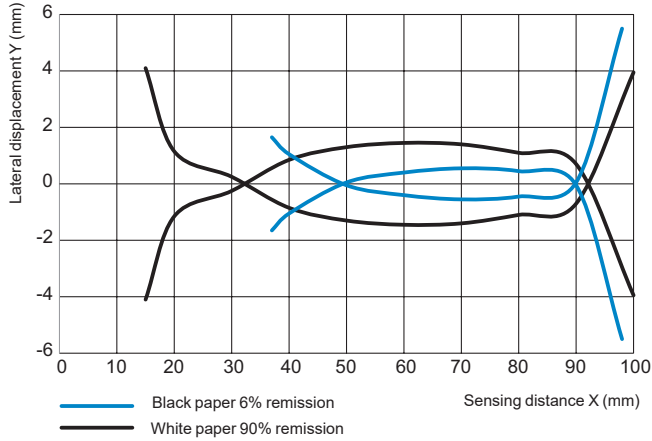

(1): Sensor
 (2): Object (200 mm square white and black mat paper)
 X: Sensing distance (mm)
 Y: Lateral displacement (mm)

Lateral displacement (preset 200 mm)

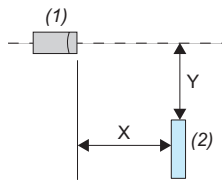
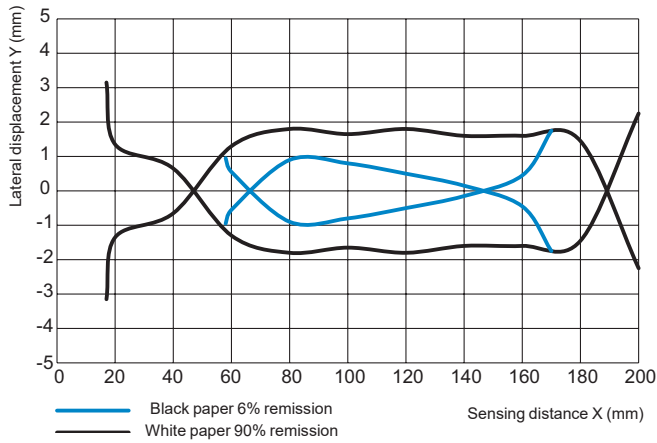

(1): Sensor
 (2): Object (200 mm square white and black mat paper)
 X: Sensing distance (mm)
 Y: Lateral displacement (mm)

Light beam diameter

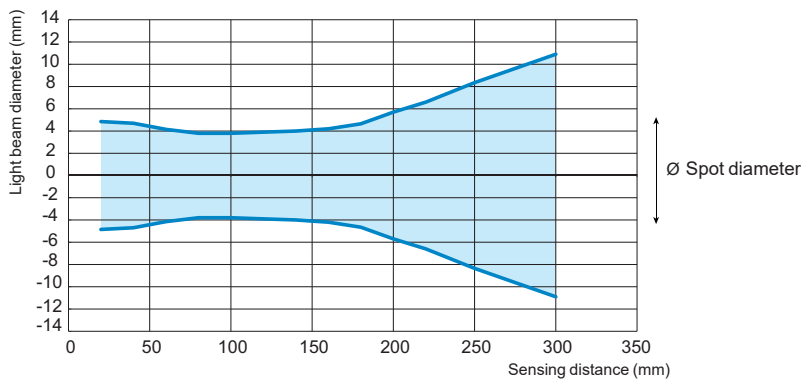

Minimum distance between the object to be detected and a white background

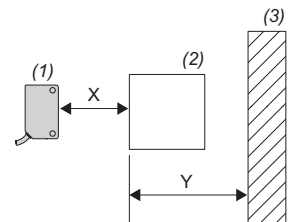
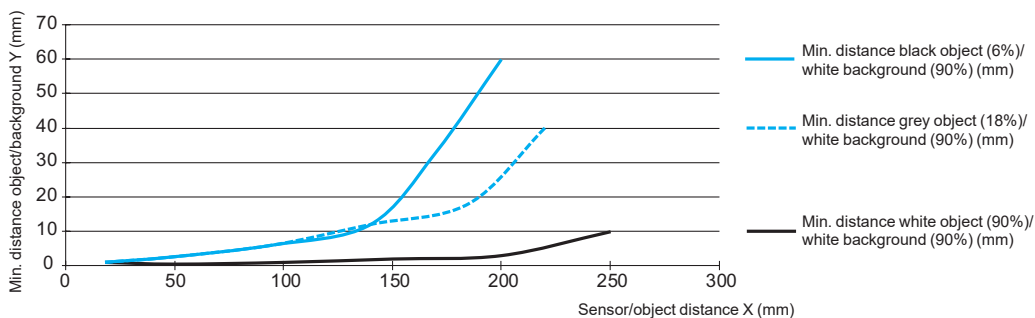

(1): Sensor
 (2): Object
 (3): Background
 X: Sensor/object distance (mm)
 Y: Min. distance object/background (mm)

Photo-electric sensors

XUM, general purpose, single mode function

Miniature design, plastic

Three-wire DC, solid-state output

Detection curves (continued)

Diffuse system: XUM4, XUM5 and XUM6

Object size/sensing distance

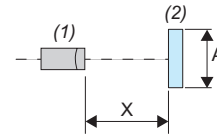
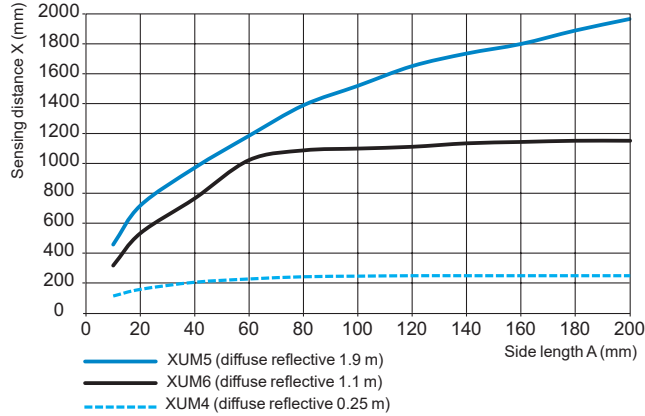

(1): Sensor
 (2): Object (white mat paper of A mm square)
 A: Side length (mm)
 X: Sensing distance (mm)

Lateral displacement

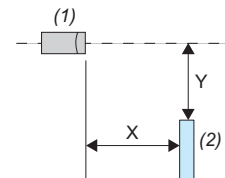
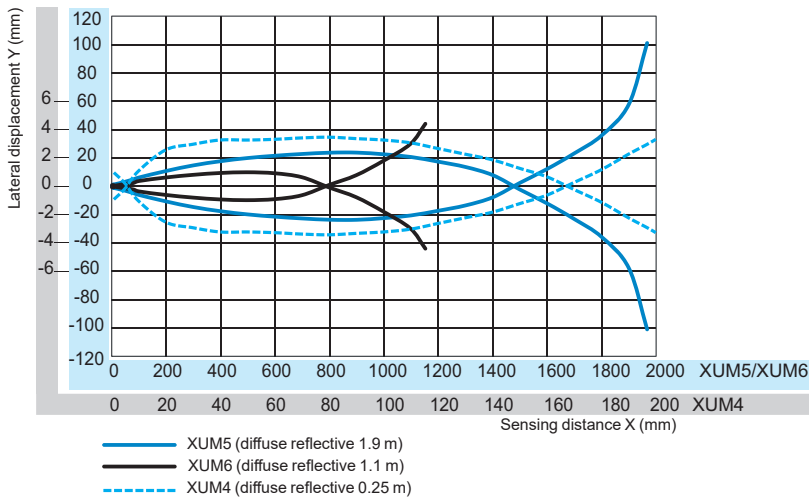

(1): Sensor
 (2): Object (200 x 200 mm square white paper)
 X: Sensing distance (mm)
 Y: Lateral displacement (mm)

Excess gain

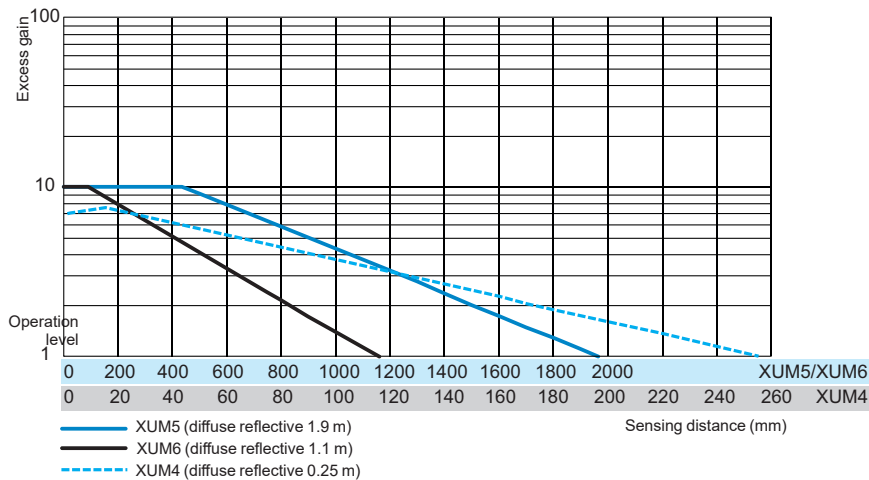

Photo-electric sensors

XUM, general purpose, single mode function

Miniature design, plastic

Three-wire DC, solid-state output

Thru-beam system

Pre-cabled and pigtail versions

Transmitter

Description - XUM2A●XBL2,
XUM2A●●BL03●●●

Dimensions - XUM2A●XBL2,
XUM2A●●BL03●●●

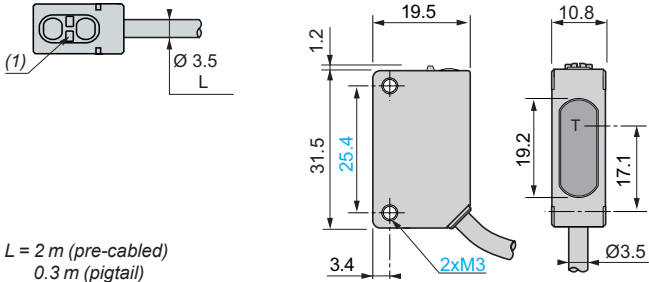

L = 2 m (pre-cabled)
0.3 m (pigtail)

Receiver

Description - XUM2A●XBL2,
XUM2A●●BL03●●●

Dimensions - XUM2A●XBL2,
XUM2A●●BL03●●●

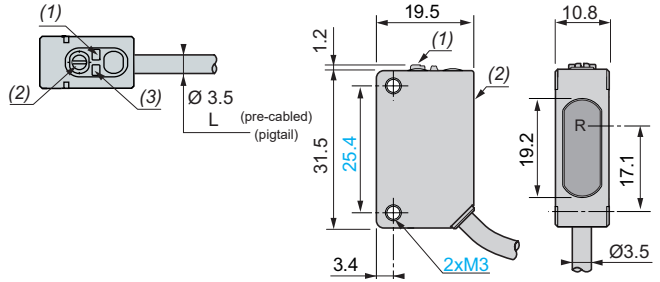

M8 connector version

Transmitter

Description - XUM2A●XBM8

Dimensions - XUM2A●XBM8

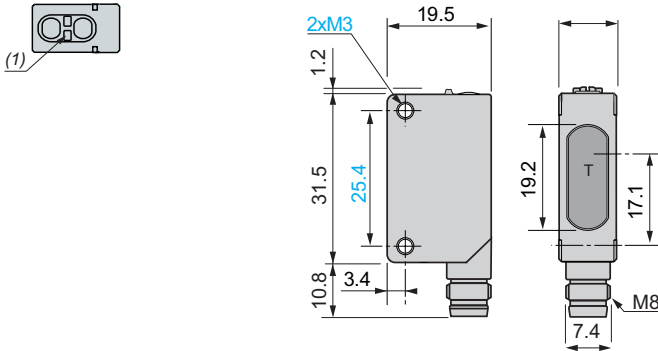

Receiver

Description - XUM2A●XBM8

Dimensions - XUM2A●XBM8

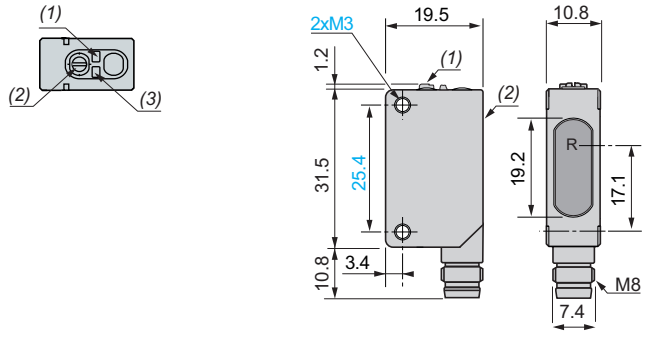

(1) Power ON indicator (green)

T: Transmission

(1) Output indicator (yellow)

(2) Setting potentiometer

(sensitivity)

(3) Power ON indicator (green)

R: Reception

(1) Setting potentiometer (sensitivity)

(2) Setting potentiometer (NO/NC)

Polarised reflex system

Pre-cabled and pigtail versions

Description - XUM9A●XBL2,
XUM9A●●BL03●●●

Dimensions - XUM9A●XBL2,
XUM9A●●BL03●●●

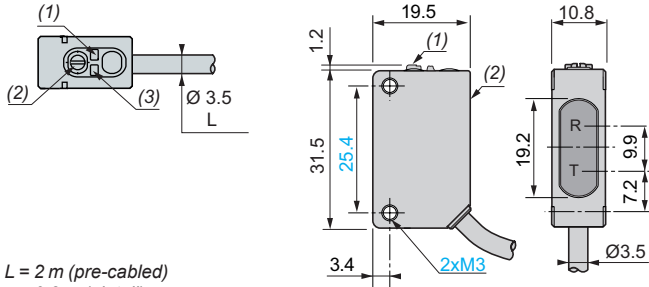

L = 2 m (pre-cabled)
0.3 m (pigtail)

M8 connector version

Description - XUM9A●XBM8

Dimensions - XUM9A●XBM8

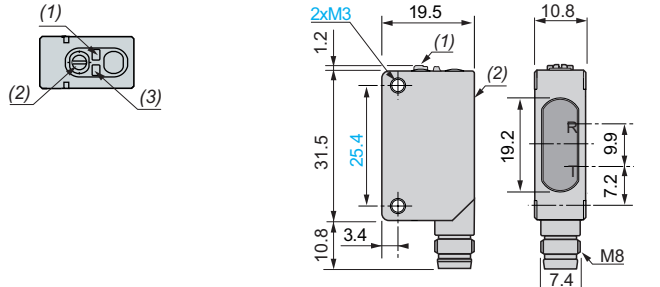

Background suppression system

Pre-cabled version

Description - XUM8A●XBL2

Dimensions - XUM8A●XBL2

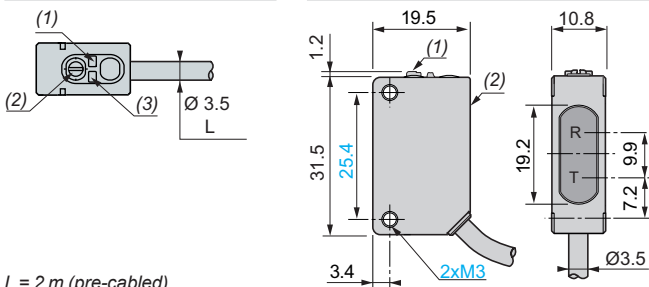

L = 2 m (pre-cabled)
0.3 m (pigtail)

M8 connector version

Description - XUM8A●XBM8

Dimensions - XUM8A●XBM8

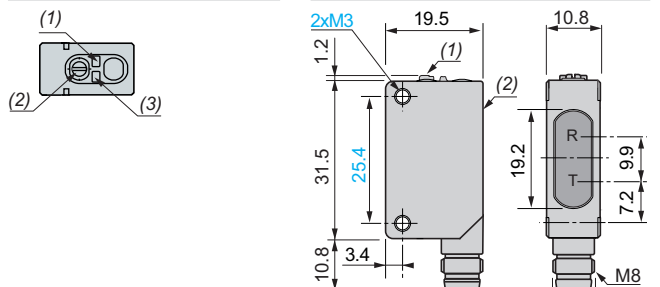

Diffuse system

Pre-cabled and pigtail versions

Description - XUM5A●XBL2,
XUM6A●XBL2, XUM4A●XBL2,
XUM●A●●BL03●●

Dimensions - XUM5A●XBL2,
XUM6A●XBL2, XUM4A●XBL2,
XUM●A●●BL03●●

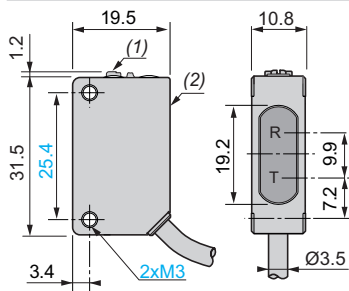
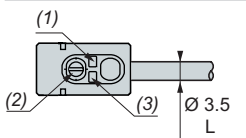

L = 2 m (pre-cabled)
0.3 m (pigtail)

- (1) Output indicator (yellow)
- (2) Setting potentiometer (sensitivity)
- (3) Stability indicator (green)

- R: Reception
- T: Transmission
- (1) Setting potentiometer (sensitivity)
- (2) Setting potentiometer (NO/NC)

M8 connector version

Description - XUM5A●XBM8,
XUM6A●XBM8, XUM4A●XBM8

Dimensions - XUM5A●XBM8,
XUM6A●XBM8, XUM4A●XBM8

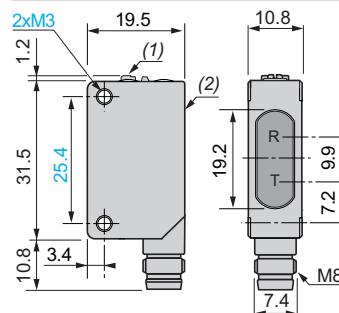
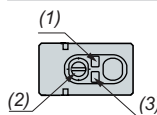

- (1) Output indicator (yellow)
- (2) Setting potentiometer (sensitivity)
- (3) Stability indicator (green)

- R: Reception
- T: Transmission
- (1) Setting potentiometer (sensitivity)
- (2) Setting potentiometer (NO/NC)

Accessories

Setting-up accessory

XUZASM05

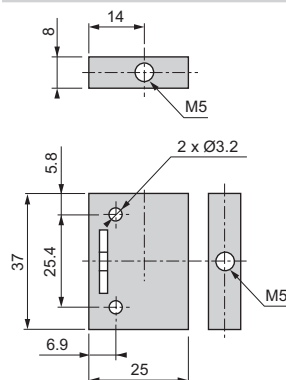

Diaphragms

XUZDVM●●

XUZDHM●●

XUZDRM●●

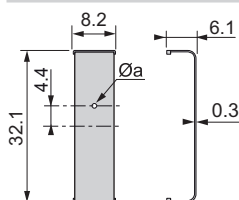
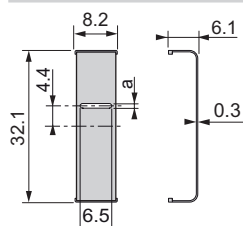
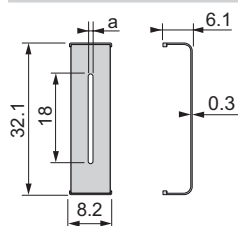

Reference	a (mm)
XUZDVM05	0.5
XUZDVM10	1
XUZDVM20	2
XUZDHM05	0.5
XUZDHM10	1
XUZDHM20	2
XUZDRM05	Ø 0.5
XUZDRM10	Ø 1
XUZDRM20	Ø 2

Photo-electric sensors

XUB general purpose, single mode function

Cylindrical miniature design 18, plastic, kits

Four-wire DC, solid-state output

Wire setting for NO/NC



Thru-beam system with adjustable sensitivity

Max./operating sensing distance (Sn)/ Line of sight	Function	Output	Connection	Reference	Weight (kg)
15 m/20 m Along case axis	NO/NC (Dark ON/Light ON) configuration by IO-Link and/or by wire on the receiver	Autodetect PNP/NPN	M12 connector (4-pin)	XUB2APYNM12	0.060
12 m/12 m 90° to case axis	NO/NC (Dark ON/Light ON) configuration by IO-Link and/or by wire on the receiver		M12 connector (4-pin)	XUB2APYWM12	0.060

Transmitter + receiver					
30 m/20 m Along case axis	NO/NC (Dark ON/Light ON) configuration by wire on the receiver	NPN	Pre-cabled (L = 2 m)	XUB2ANXNL2	0.171
	NO/NC (Dark ON/Light ON) configuration by wire on the receiver		M12 connector (4-pin)	XUB2ANXNM12	0.060
17 m/12 m 90° to case axis	NO/NC (Dark ON/Light ON) configuration by wire on the receiver	NPN	Pre-cabled (L = 2 m)	XUB2ANXWL2	0.171
	NO/NC (Dark ON/Light ON) configuration by wire on the receiver		M12 connector (4-pin)	XUB2ANXWM12	0.060
30 m/20 m Along case axis	NO/NC (Dark ON/Light ON) configuration by wire on the receiver	PNP	Pre-cabled (L = 2 m)	XUB2APXNL2	0.171
	NO/NC (Dark ON/Light ON) configuration by wire on the receiver		M12 connector (4-pin)	XUB2APXNM12	0.060
17 m/12 m 90° to case axis	NO/NC (Dark ON/Light ON) configuration by wire on the receiver	PNP	Pre-cabled (L = 2 m)	XUB2APXWL2	0.171
	NO/NC (Dark ON/Light ON) configuration by wire on the receiver		M12 connector (4-pin)	XUB2APXWM12	0.060

Accessories

IO-Link Master

See page 78.

Fixing and other accessories

See page 82.

Cabling accessories

See page 88.

Photo-electric sensors

XUB general purpose, single mode function

Cylindrical miniature design 18, plastic

Four-wire DC, solid-state output

Wire setting for NO/NC

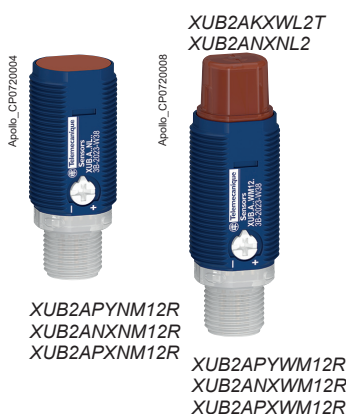

Thru-beam system with adjustable sensitivity

Max./operating sensing distance (Sn)/Line of sight	Function	Output	Connection	Reference	Weight (kg)
Transmitter only (1)					
30 m/20 m Along case axis	–	–	Pre-cabled (L = 2 m)	XUB2AKXNL2T	0.095
			M12 connector (4-pin)	XUB2AKXNM12T	0.040
17 m/12 m 90° to case axis	–	–	Pre-cabled (L = 2 m)	XUB2AKXWL2T	0.095
			M12 connector (4-pin)	XUB2AKXWM12T	0.040

Receiver IO-Link only

30 m/20 m Along case axis	NO/NC (Dark ON/Light ON) configuration by wire or IO-Link	Autodetect PNP/NPN	M12 connector (4-pin)	XUB2APYNM12R	0.040
			M12 connector (4-pin)	XUB2APYWM12R	0.040
17 m/12 m 90° to case axis	NO/NC (Dark ON/Light ON) configuration by wire or IO-Link	Autodetect PNP/NPN	M12 connector (4-pin)	XUB2APYNM12R	0.040
			M12 connector (4-pin)	XUB2APYWM12R	0.040

Receiver only

30 m/20 m Along case axis	NO/NC (Dark ON/Light ON) configuration by wire	NPN	Pre-cabled (L = 2 m)	XUB2ANXNL2R	0.095
			M12 connector (4-pin)	XUB2ANXNM12R	0.040
17 m/12 m 90° to case axis	NO/NC (Dark ON/Light ON) configuration by wire	NPN	Pre-cabled (L = 2 m)	XUB2ANXWL2R	0.095
			M12 connector (4-pin)	XUB2ANXWM12R	0.040
30 m/20 m Along case axis	NO/NC (Dark ON/Light ON) configuration by wire	PNP	Pre-cabled (L = 2 m)	XUB2APXNL2R	0.095
			M12 connector (4-pin)	XUB2APXNM12R	0.040
17 m/12 m 90° to case axis	NO/NC (Dark ON/Light ON) configuration by wire	NPN	Pre-cabled (L = 2 m)	XUB2ANXWL2R	0.095
			M12 connector (4-pin)	XUB2ANXWM12R	0.040
30 m/20 m Along case axis	NO/NC (Dark ON/Light ON) configuration by wire	PNP	Pre-cabled (L = 2 m)	XUB2APXWL2R	0.095
			M12 connector (4-pin)	XUB2APXWM12R	0.040

Accessories

IO-Link Master

See page 78.

Fixing and other accessories

See page 82.

Cabling accessories

See page 88.

(1) All transmitters are compatible with the receivers listed below.

Photo-electric sensors

XUB general purpose, single mode function

Cylindrical miniature design 18, metal, kits

Four-wire DC, solid-state output

Wire setting for NO/NC

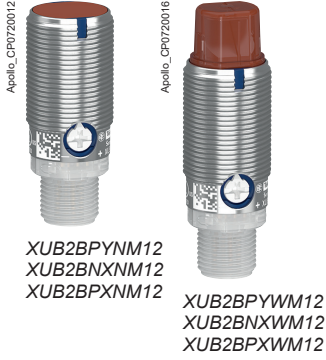

Thru-beam system with adjustable sensitivity

Max./operating sensing distance (Sn)/ Line of sight	Function	Output	Connection	Reference	Weight (kg)
---	----------	--------	------------	-----------	-------------

Transmitter + receiver IO-Link

12 m/12 m Along case axis	NO/NC (Dark ON/Light ON) configuration by IO-Link and/or by wire on the receiver	Autodetect PNP/NPN	M12 connector (4-pin)	XUB2BPYNM12	0.060
------------------------------	--	-----------------------	--------------------------	--------------------	-------

12 m/12 m 90° to case axis	NO/NC (Dark ON/Light ON) configuration by IO-Link and/or by wire on the receiver	Autodetect PNP/NPN	M12 connector (4-pin)	XUB2BPYWM12	0.060
-------------------------------	--	-----------------------	--------------------------	--------------------	-------

Transmitter + receiver

30 m/20 m Along case axis	NO/NC (Dark ON/Light ON) configuration by wire on the receiver	NPN	Pre-cabled (L = 2 m)	XUB2BNXNL2	0.192
------------------------------	--	-----	-------------------------	-------------------	-------

	NO/NC (Dark ON/Light ON) configuration by wire on the receiver	NPN	M12 connector (4-pin)	XUB2BNXNM12	0.080
--	--	-----	--------------------------	--------------------	-------

17 m/12 m 90° to case axis	NO/NC (Dark ON/Light ON) configuration by wire on the receiver	NPN	Pre-cabled (L = 2 m)	XUB2BNXWL2	0.192
-------------------------------	--	-----	-------------------------	-------------------	-------

	NO/NC (Dark ON/Light ON) configuration by wire on the receiver	NPN	M12 connector (4-pin)	XUB2BNXWM12	0.080
--	--	-----	--------------------------	--------------------	-------

30 m/20 m Along case axis	NO/NC (Dark ON/Light ON) configuration by wire on the receiver	PNP	Pre-cabled (L = 2 m)	XUB2BPXNL2	0.192
------------------------------	--	-----	-------------------------	-------------------	-------

	NO/NC (Dark ON/Light ON) configuration by wire on the receiver	PNP	M12 connector (4-pin)	XUB2BPXNM12	0.080
--	--	-----	--------------------------	--------------------	-------

17 m/12 m 90° to case axis	NO/NC (Dark ON/Light ON) configuration by wire on the receiver	PNP	Pre-cabled (L = 2 m)	XUB2BPXWL2	0.192
-------------------------------	--	-----	-------------------------	-------------------	-------

	NO/NC (Dark ON/Light ON) configuration by wire on the receiver	PNP	M12 connector (4-pin)	XUB2BPXWM12	0.080
--	--	-----	--------------------------	--------------------	-------

Accessories

IO-Link Master

See page 78.

Fixing and other accessories

See page 82.

Cabling accessories

See page 88.

Photo-electric sensors

XUB general purpose, single mode function

Cylindrical miniature design 18, metal

Four-wire DC, solid-state output

Wire setting for NO/NC



XUB2BKXNM12T

XUB2BKXWM12T



XUB2BKXNL2T

XUB2BKXWL2T

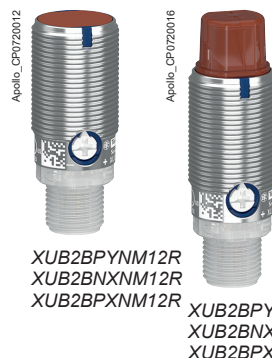

XUB2BPYNM12R
XUB2BNXNM12R
XUB2BPXNM12R

XUB2BPYWM12R
XUB2BNXWM12R
XUB2BPXWM12R



XUB2BNXNL2R
XUB2BPXNL2R

XUB2BNXWL2R
XUB2BPXWL2R

Thru-beam system with adjustable sensitivity

Max./operating sensing distance (Sn)/Line of sight	Function	Output	Connection	Reference	Weight (kg)
Transmitter only (1)					
30 m/20 m Along case axis	–	–	Pre-cabled (L = 2 m)	XUB2BKXNL2T	0.095
			M12 connector (4-pin)	XUB2BKXNM12T	0.040
17 m/12 m 90° to case axis	–	–	Pre-cabled (L = 2 m)	XUB2BKXWL2T	0.095
			M12 connector (4-pin)	XUB2BKXWM12T	0.040

Receiver IO-Link only

30 m/20 m Along case axis	NO/NC (Dark ON/Light ON) configuration by wire or IO-Link	Autodetect PNP/NPN	M12 connector (4-pin)	XUB2BPYNM12R	0.040
			M12 connector (4-pin)	XUB2BPYWM12R	0.040
17 m/12 m 90° to case axis	NO/NC (Dark ON/Light ON) configuration by wire or IO-Link	Autodetect PNP/NPN	M12 connector (4-pin)	XUB2BPYNM12R	0.040
			M12 connector (4-pin)	XUB2BPYWM12R	0.040

Receiver only

30 m/20 m Along case axis	NO/NC (Dark ON/Light ON) configuration by wire	NPN	Pre-cabled (L = 2 m)	XUB2BNXNL2R	0.095
			M12 connector (4-pin)	XUB2BNXNM12R	0.040
		PNP	Pre-cabled (L = 2 m)	XUB2BPXNL2R	0.095
			M12 connector (4-pin)	XUB2BPXNM12R	0.040
17 m/12 m 90° to case axis	NO/NC (Dark ON/Light ON) configuration by wire	NPN	Pre-cabled (L = 2 m)	XUB2BNXWL2R	0.095
			M12 connector (4-pin)	XUB2BNXWM12R	0.040
		PNP	Pre-cabled (L = 2 m)	XUB2BPXWL2R	0.095
			M12 connector (4-pin)	XUB2BPXWM12R	0.040

Accessories

IO-Link Master

See page 78.

Fixing and other accessories

See page 82.

Cabling accessories

See page 88.

(1) All transmitters are compatible with the receivers listed below.

Photo-electric sensors

XUB general purpose, single mode function

Cylindrical miniature design 18, plastic

Four-wire DC, solid-state output

Wire setting for NO/NC



XUB●APYNM12
XUB●ANXNM12
XUB●APXNM12



XUB●APYWM12
XUB6●●●●



XUB●ANXNL2
XUB●APXNL2



XUB6●●●●

Diffuse system with adjustable sensitivity, IO-Link

Max./operating sensing distance (Sn)/Line of sight	Function	Output	Connection	Reference	Weight (kg)
--	----------	--------	------------	-----------	-------------

Long range, red LED emission

1 m/0.7 m Along case axis	NO/NC (Light ON/Dark ON) configuration by wire or IO-Link	Autodetect PNP/NPN	M12 connector (4-pin)	XUB5APYNM12	0.040
------------------------------	---	-----------------------	--------------------------	--------------------	-------

Medium range, red LED emission

0.6 m/0.42 m Along case axis	NO/NC (Light ON/Dark ON) configuration by wire or IO-Link	Autodetect PNP/NPN	M12 connector (4-pin)	XUB6APYNM12	0.040
---------------------------------	---	-----------------------	--------------------------	--------------------	-------

0.5 m/0.35 m 90° to case axis	NO/NC (Light ON/Dark ON) configuration by wire or IO-Link	Autodetect PNP/NPN	M12 connector (4-pin)	XUB6APYWM12	0.040
----------------------------------	---	-----------------------	--------------------------	--------------------	-------

Diffuse system with adjustable sensitivity

Max./operating sensing distance (Sn)/Line of sight	Function	Output	Connection	Reference	Weight (kg)
--	----------	--------	------------	-----------	-------------

Long range, red LED emission

1 m/0.7 m Along case axis	NO/NC (Light ON/Dark ON) configuration by wire	NPN	Pre-cabled (L = 2 m)	XUB5ANXNL2	0.095
			M12 connector (4-pin)	XUB5ANXNM12	0.040
		PNP	Pre-cabled (L = 2 m)	XUB5APXNL2	0.095
			M12 connector (4-pin)	XUB5APXNM12	0.040

Medium range, red LED emission

0.6 m/0.42 m Along case axis	NO/NC (Light ON/Dark ON) configuration by wire	NPN	Pre-cabled (L = 2 m)	XUB6ANXNL2	0.095
			M12 connector (4-pin)	XUB6ANXNM12	0.040
		PNP	Pre-cabled (L = 2 m)	XUB6APXNL2	0.095
			M12 connector (4-pin)	XUB6APXNM12	0.040
0.5 m/0.35 m 90° to case axis	NO/NC (Light ON/Dark ON) configuration by wire	NPN	Pre-cabled (L = 2 m)	XUB6ANXWL2	0.095
			M12 connector (4-pin)	XUB6ANXWM12	0.040
		PNP	Pre-cabled (L = 2 m)	XUB6APXWL2	0.095
			M12 connector (4-pin)	XUB6APXWM12	0.040

Accessories

IO-Link Master

See page 78.

Fixing and other accessories

See page 82.

Cabling accessories

See page 88.

Photo-electric sensors

XUB general purpose, single mode function

Cylindrical miniature design 18, metal

Four-wire DC, solid-state output

Wire setting for NO/NC

Apollo_CP0720012



XUB5BPYNM12
XUB5BNXNM12
XUB5BPXNM12

Apollo_CP0720016



XUB6BPYWM12
XUB6BNXWM12
XUB6BPXWM12

Apollo_CP0720010



XUB5BNXNL2
XUB5BPXNL2

Apollo_CP0720014



XUB6BNXWL2
XUB6BPXWL2

Diffuse system with adjustable sensitivity, IO-Link

Max./operating sensing distance (Sn)/Line of sight	Function	Output	Connection	Reference	Weight (kg)
--	----------	--------	------------	-----------	-------------

Long range, red LED emission

1 m/0.7 m Along case axis	NO/NC (Light ON/Dark ON) configuration by wire or IO-Link	Autodetect PNP/NPN	M12 connector (4-pin)	XUB5BPYNM12	0.040
------------------------------	---	-----------------------	--------------------------	-------------	-------

Medium range, red LED emission

0.6 m/0.42 m Along case axis	NO/NC (Light ON/Dark ON) configuration by wire or IO-Link	Autodetect PNP/NPN	M12 connector (4-pin)	XUB6BPYNM12	0.040
---------------------------------	---	-----------------------	--------------------------	-------------	-------

0.5 m/0.35 m 90° to case axis	NO/NC (Light ON/Dark ON) configuration by wire or IO-Link	Autodetect PNP/NPN	M12 connector (4-pin)	XUB6BPYWM12	0.040
----------------------------------	---	-----------------------	--------------------------	-------------	-------

Diffuse system with adjustable sensitivity

Max./operating sensing distance (Sn)/Line of sight	Function	Output	Connection	Reference	Weight (kg)
--	----------	--------	------------	-----------	-------------

Long range, red LED emission

1 m/0.7 m Along case axis	NO/NC (Light ON/Dark ON) configuration by wire	NPN	Pre-cabled (L = 2 m)	XUB5BNXNL2	0.095
			M12 connector (4-pin)	XUB5BNXNM12	0.040

PNP	Pre-cabled (L = 2 m)	XUB5BPXNL2	0.095
-----	-------------------------	------------	-------

M12 connector (4-pin)	XUB5BPXNM12	0.040
--------------------------	-------------	-------

Medium range, red LED emission

0.6 m/0.42 m Along case axis	NO/NC (Light ON/Dark ON) configuration by wire	NPN	Pre-cabled (L = 2 m)	XUB6BNXNL2	0.095
			M12 connector (4-pin)	XUB6BNXNM12	0.040

PNP	Pre-cabled (L = 2 m)	XUB6BPXNL2	0.095
-----	-------------------------	------------	-------

M12 connector (4-pin)	XUB6BPXNM12	0.040
--------------------------	-------------	-------

0.5 m/0.35 m 90° to case axis	NO/NC (Light ON/Dark ON) configuration by wire	NPN	Pre-cabled (L = 2 m)	XUB6BNXWL2	0.095
			M12 connector (4-pin)	XUB6BNXWM12	0.040

PNP	Pre-cabled (L = 2 m)	XUB6BPXWL2	0.095
-----	-------------------------	------------	-------

M12 connector (4-pin)	XUB6BPXWM12	0.040
--------------------------	-------------	-------

Accessories

IO-Link Master

See page 78.

Fixing and other accessories

See page 82.

Cabling accessories

See page 88.

Photo-electric sensors

XUB general purpose, single mode function

Cylindrical miniature design 18, plastic

Four-wire DC, solid-state output

Wire setting for NO/NC



XUB9APYNM12
XUB9ANXNM12
XUB9APXNM12



XUB9APYWM12
XUB9ANXWM12
XUB9APXWM12



XUB9ANXNL2
XUB9APXNL2



XUB9ANXWL2
XUB9APXWL2

Polarised reflex system with adjustable sensitivity, IO-Link

Plastic, red LED emission

Max./operating sensing distance (Sn)/Line of sight	Function	Output	Connection	Reference	Weight (kg)
7 m/5 m Along case axis	NO/NC (Dark ON/Light ON) configuration by wire or IO-Link	Autodetect PNP/NPN	M12 connector (4-pin)	XUB9APYNM12	0.040
5.5 m/4 m 90° to case axis	NO/NC (Dark ON/Light ON) configuration by wire or IO-Link	Autodetect PNP/NPN	M12 connector (4-pin)	XUB9APYWM12	0.040

Polarised reflex system with adjustable sensitivity

Plastic, red LED emission

Max./operating sensing distance (Sn)/Line of sight	Function	Output	Connection	Reference	Weight (kg)		
7 m/5 m Along case axis	NO/NC (Dark ON/Light ON) configuration by wire	NPN	Pre-cabled (L = 2 m)	XUB9ANXNL2	0.095		
			M12 connector (4-pin)	XUB9ANXNM12	0.040		
		PNP	Pre-cabled (L = 2 m)	XUB9APXNL2	0.095		
			M12 connector (4-pin)	XUB9APXNM12	0.040		
		5.5 m/4 m 90° to case axis	NO/NC (Dark ON/Light ON) configuration by wire	NPN	Pre-cabled (L = 2 m)	XUB9ANXWL2	0.095
					M12 connector (4-pin)	XUB9ANXWM12	0.040
PNP	Pre-cabled (L = 2 m)			XUB9APXWL2	0.095		
	M12 connector (4-pin)			XUB9APXWM12	0.040		

Accessories

IO-Link Master

See page 78.

Fixing and other accessories

See page 82.

Cabling accessories

See page 88.

Photo-electric sensors

XUB general purpose, single mode function

Cylindrical miniature design 18, metal

Four-wire DC, solid-state output

Wire setting for NO/NC



XUB9BPYNM12
XUB9BNXNM12
XUB9BPXNM12



XUB9BPYWM12
XUB9BNXWM12
XUB9BPXWM12



XUB9BNXNL2
XUB9BPXNL2



XUB9BNXWL2
XUB9BPXWL2

Polarised reflex system with adjustable sensitivity, IO-Link

Metal, red LED emission

Max./operating sensing distance (Sn)/Line of sight	Function	Output	Connection	Reference	Weight (kg)
7 m/5 m Along case axis	NO/NC (Dark ON/Light ON) configuration by wire or IO-Link	Autodetect PNP/NPN	M12 connector (4-pin)	XUB9BPYNM12	0.040
5.5 m/4 m 90° to case axis	NO/NC (Dark ON/Light ON) configuration by wire or IO-Link	Autodetect PNP/NPN	M12 connector (4-pin)	XUB9BPYWM12	0.040

Polarised reflex system with adjustable sensitivity

Max./operating sensing distance (Sn)/Line of sight	Function	Output	Connection	Reference	Weight (kg)		
7 m/5 m Along case axis	NO/NC (Dark ON/Light ON) configuration by wire	NPN	Pre-cabled (L = 2 m)	XUB9BNXNL2	0.095		
			M12 connector (4-pin)	XUB9BNXNM12	0.040		
		PNP	Pre-cabled (L = 2 m)	XUB9BPXNL2	0.095		
			M12 connector (4-pin)	XUB9BPXNM12	0.040		
		5.5 m/4 m 90° to case axis	NO/NC (Dark ON/Light ON) configuration by wire	NPN	Pre-cabled (L = 2 m)	XUB9BNXWL2	0.095
					M12 connector (4-pin)	XUB9BNXWM12	0.040
PNP	Pre-cabled (L = 2 m)	XUB9BPXWL2	0.095				
		M12 connector (4-pin)	XUB9BPXWM12	0.040			

Accessories

IO-Link Master

See page 78.

Fixing and other accessories

See page 82.

Cabling accessories

See page 88.

Photo-electric sensors

XUB general purpose, single mode function
Cylindrical miniature design 18, plastic
Four-wire DC, solid-state output
Wire setting for NO/NC

Characteristics					
Sensor type		XUB2APY●M12, XUB2BPY●M12, XUB2A●X●M12, XUB2A●X●M12 XUB2APY●M12R, XUB2BPY●M12R, XUB2A●X●M12T, XUB2A●X●M12R, XUB2B●X●M12T, XUB2B●X●M12R, XUB5APYNM12, XUB5BPYNM12, XUB5A●X●M12, XUB5B●X●M12, XUB6APY●M12, XUB6APY●M12, XUB6A●X●M12, XUB6B●X●M12, XUB9APY●M12, XUB9BPY●M12 XUB9A●X●M12, XUB9B●X●M12		XUB2A●X●L2, XUB2A●X●L2, XUB2B●X●L2, XUB2B●X●L2, XUB2A●X●L2T, XUB2A●X●L2R, XUB2B●X●L2T, XUB2B●X●L2R, XUB5A●X●L2, XUB5B●X●L2, XUB6A●X●L2, XUB6B●X●L2, XUB9A●X●L2, XUB9B●X●L2	
Product certifications		CE, UKCA, cULus, ECOLAB			
Connection	Connector	M12			
	Pre-cabled	–			
		Length: 2 m			
Sensing distance Excess gain = 1: maximum sensing distance Excess gain = 2 : nominal sensing distance	Thru-beam system XUB2	Along case axis (axial)	m	30 (with excess gain = 1) 20 (with excess gain = 2)	
		90° to case axis (radial)	m	17 (with excess gain = 1) 12 (with excess gain = 2)	
	Diffuse system XUB5 (using a white paper 200 x 200 mm)	Along case axis (axial)	m	1 (with excess gain = 1) 0.7 (with excess gain = 2)	
		Along case axis (axial)	m	0.6 (with excess gain = 1) 0.42 (with excess gain = 2)	
	Diffuse system XUB6 (using a white paper 200 x 200 mm)	90° to case axis (radial)	m	0.5 (with excess gain = 1) 0.35 (with excess gain = 2)	
		Polarised reflex system XUB9 (using a 50 x 50 mm reflector XUZC50)	Along case axis	m	7 (with excess gain = 1) 5 (with excess gain = 2)
90° to case axis	m		5.5 (with excess gain = 1) 4 (with excess gain = 2)		
Blind zone		mm	0 (white object and potentiometer max.)		
Sensing distance setting		Potentiometer 1 turn (+/- 220 degrees)			
Colour of detection light beam		Red			
Output type		PNP/NPN (or autodetect PNP/NPN with IO-Link)			
Hysteresis		2% < H < 20% at Sn			
Degree of protection	Conforming to IEC 60529		IP65, IP67		
	Conforming to DIN 40050-9		IP69K (M12 connector versions only)		
Artificial optical radiation	Conforming to IEC 62471		Class 0 (risk exempt)		
Radiated disturbances emissions	Conforming to EN 55011/CISPR 1		Class A		
Storage temperature			°C	-40...+70	
Operating temperature			°C	-30...+55	
Materials	Case	XUB●A	PBT/PC		
		XUB●B	Brass		
	Back cap	MABS			
	Potentiometer screw	PBT			
	Lens cover	PMMA			
	Cable	–		PVC	
Vibration resistance	Conforming to IEC 60068-2-6		Frequency range: 10 to 55 Hz Acceleration: 7 gn		
Shock resistance	Conforming to IEC 60068-2-27		Peak acceleration: 30 gn Duration of the pulse: 11 ms		
Rated supply voltage			V	12...24 --- with protection against reverse polarity	
Voltage limits (including ripple)			V	10...30 ---	
Current consumption, no-load			mA	< 20/IO-Link: < 30	
Switching capacity			mA	100	
Voltage drop, closed state			V	≤ 2	
Maximum switching frequency			Hz	1000	
Delays	First-up			ms	< 100/IO-Link : < 300
	Response			ms	0.5 max.
	Recovery			ms	0.5 max

Photo-electric sensors

XUB general purpose, single mode function

Cylindrical miniature design 18

Four-wire DC, solid-state output

Wire setting for NO/NC

Wiring schemes

Thru-beam system

M12 connector - 4 pins, plastic and metal, IO-Link

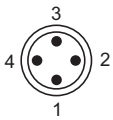

Pin	Signal	Definition
1	+	+ 24 V
2	IN	+ = NO - = NC Open = NO
3	-	0 V
4	Q	Switching signal (SIO)
	C	IO-Link communication

Autodetect PNP/NPN or by IO-Link

XUB2●PYNM12R, XUB2●PYWM12R, XUB2●KXNM12T, XUB2●KXWM12T

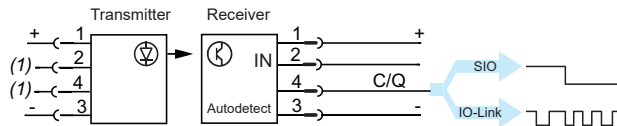

Note: IO-Link files available on our website www.telemecaniquesensors.com/iolink

M12 connector - 4 pins, plastic and metal

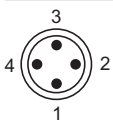

Pin	Signal	Definition
1	+	+ 24 V
2	IN	+ = NO - = NC Open = NO
3	-	0 V
4	Q	Switching signal (SIO)

PNP

XUB2●PXNM12R, XUB2●PXWM12R,
XUB2●KXNM12T, XUB2●KXWM12T

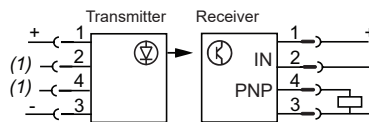

NPN

XUB2●NXNM12R, XUB2●NXWM12R,
XUB2●KXNM12T, XUB2●KXWM12T

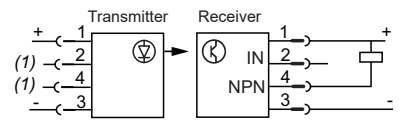

Pre-cabled - 4 wires, plastic and metal

+BN (Brown)
IN (input) GY (Grey)
OUT (output) BK (Black)
-BU (Blue)

PNP

XUB2●PXNL2R, XUB2●APXWL2R,
XUB2●KXNL2T, XUB2●KXWL2T

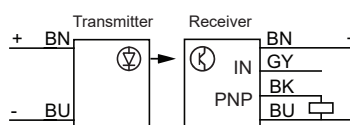

NPN

XUB2●NXNL2R, XUB2●NXWL2R,
XUB2●KXNL2T, XUB2●KXWL2T

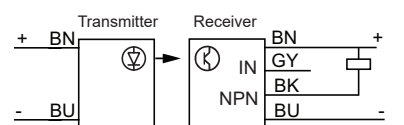

Diffuse system

M12 connector - 4 pins, plastic and metal, IO-Link

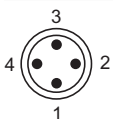

Pin	Signal	Definition
1	+	+ 24 V
2	IN	+ = NO - = NC Open = NO
3	-	0 V
4	Q	Switching signal (SIO)
	C	IO-Link communication

Autodetect PNP/NPN or by IO-Link

XUB5APYNM12, XUB6APYNM12, XUB6APYWM12, XUB5BPYNM12, XUB6BPYNM12,
XUB6BPYWM12

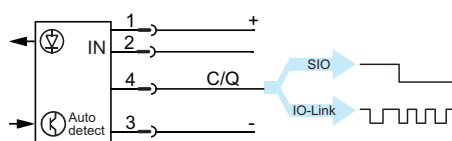

Note: IO-Link files available on our website www.telemecaniquesensors.com/iolink

M12 connector - 4 pins, plastic and metal

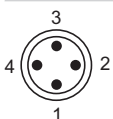

Pin	Signal	Definition
1	+	+ 24 V
2	IN	+ = NO - = NC Open = NO
3	-	0 V
4	Q	Switching signal (SIO)

PNP

XUB5APXNM12, XUB6APXNM12,
XUB6APXWM12, XUB5BPXNM12,
XUB6BPXNM12, XUB6BPXWM12,

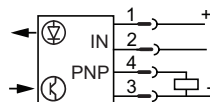

NPN

XUB5ANXNM12, XUB6ANXNM12,
XUB6ANXWM12, XUB5BNXNM12,
XUB6BNXNM12, XUB6BNXWM12

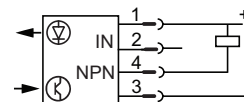

Pre-cabled - 4 wires, plastic and metal

+BN (Brown)
IN (input) GY (Grey)
OUT (output) BK (Black)
-BU (Blue)

PNP

XUB5APXNL2, XUB6APXNL2, XUB6APXWL2,
XUB5BPXNL2, XUB6BPXNL2, XUB6BPXWL2

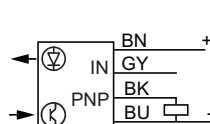

NPN

XUB5ANXNL2, XUB6ANXNL2,
XUB6ANXWL2, XUB5BNXNL2,
XUB6BNXNL2, XUB6BNXWL2

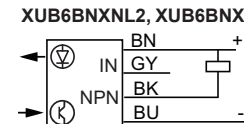

(1) Not connected.

Photo-electric sensors

XUB general purpose, single mode function

Cylindrical miniature design 18

Four-wire DC, solid-state output

Wire setting for NO/NC

Wiring schemes (continued)

Polarised reflex system

M12 connector - 4 pins, plastic and metal, IO-Link

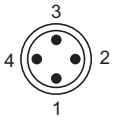

Pin	Signal	Definition
1	+	+ 24 V $\overline{\text{---}}$
2	IN	+ = NO - = NC Open = NO
3	-	0 V $\overline{\text{---}}$
4	Q	Switching signal (SIO)
	C	IO-Link communication

Autodetect PNP/NPN or by IO-Link

XUB9APYNM12, XUB9APYW12, XUB9BPYNM12, XUB9BPYW12

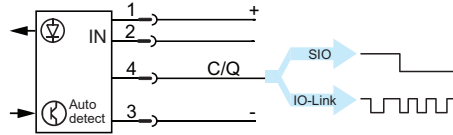

Note: IO-Link files available on our website www.telemecanique.com/iolink

M12 connector - 4 pins, plastic and metal

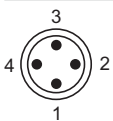

Pin	Signal	Definition
1	+	+ 24 V $\overline{\text{---}}$
2	IN	+ = NO - = NC Open = NO
3	-	0 V $\overline{\text{---}}$
4	Q	Switching signal (SIO)

PNP

XUB9APXNM12, XUB9APXW12,
XUB9BPXNM12, XUB9BPXW12

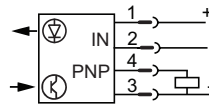

NPN

XUB9ANXNM12, XUB9ANXW12,
XUB9BNXNM12, XUB9BNXW12

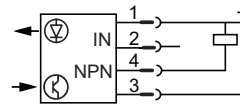

Pre-cabled - 4 wires, plastic and metal

+BN (Brown)
IN (input) GY (Grey)
OUT (output) BK (Black)
-BU (Blue)

PNP

XUB9APXNL2, XUB9BAPXWL2,
XUB9BPXNL2, XUB9BPXWL2

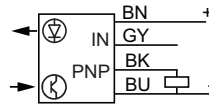

NPN

XUB9ANXNL2, XUB9ANXWL2,
XUB9BNXNL2, XUB9BNXWL2

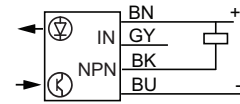

Photo-electric sensors

XUB general purpose, single mode function

Cylindrical miniature design 18

Four-wire DC, solid-state output

Wire setting for NO/NC

Detection curves

Thru-beam system: XUB2

Lateral displacement

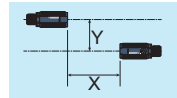
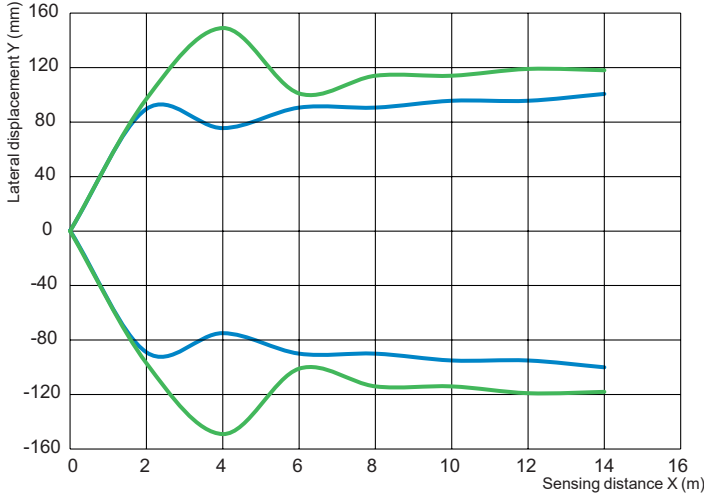

Line of sight: along case axis (axial)

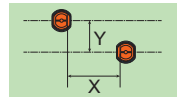

Line of sight: 90° to case axis (radial)

Light beam diameter

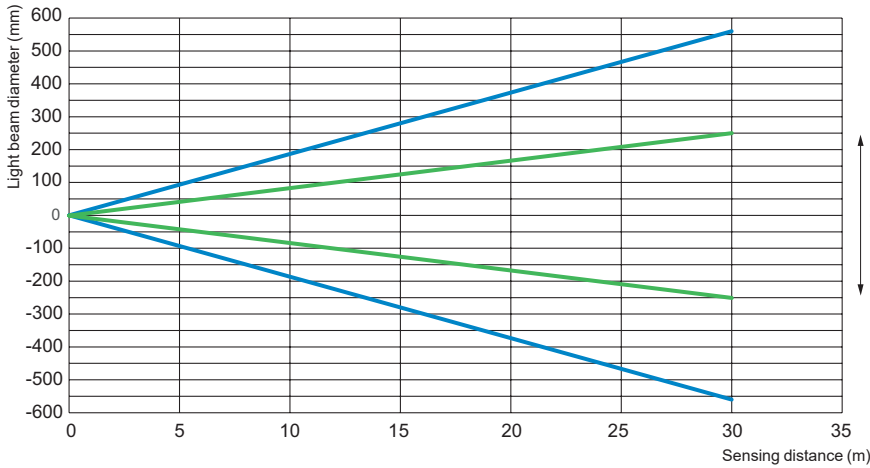

∅ Spot diameter

Line of sight: 90° to case axis (radial)

Line of sight: along case axis (axial)

Excess gain

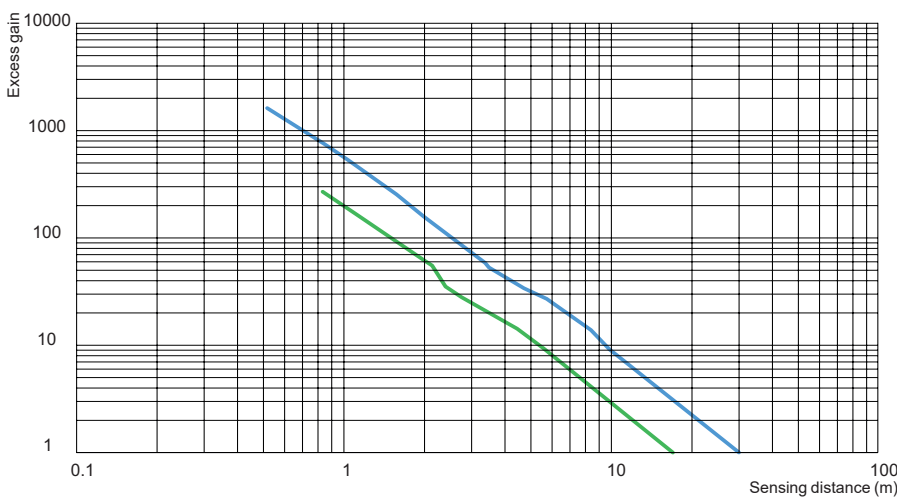

Line of sight: 90° to case axis (radial)

Line of sight: Along case axis (axial)

Photo-electric sensors

XUB general purpose, single mode function

Cylindrical miniature design 18

Four-wire DC, solid-state output

Wire setting for NO/NC

Detection curves (continued)

Diffuse system: XUB5 and XUB6

Minimum object size/sensing distance. Line of sight: along case axis (axial)

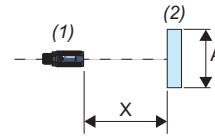
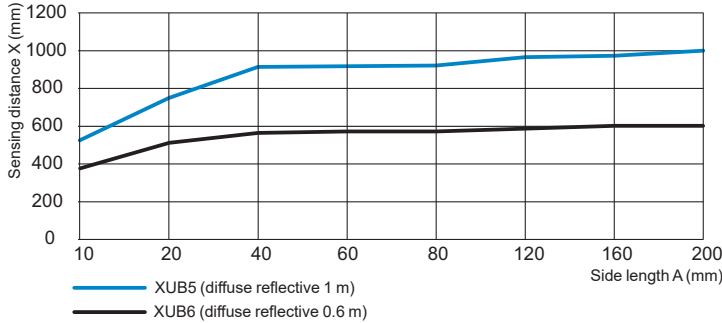

(1): Sensor
 (2): Object (white matt paper of A mm square)
 A: Side length (mm)
 X: Sensing distance (mm)

Minimum object size/sensing distance. Line of sight: 90° to case axis (radial)

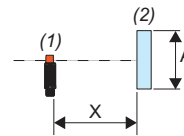
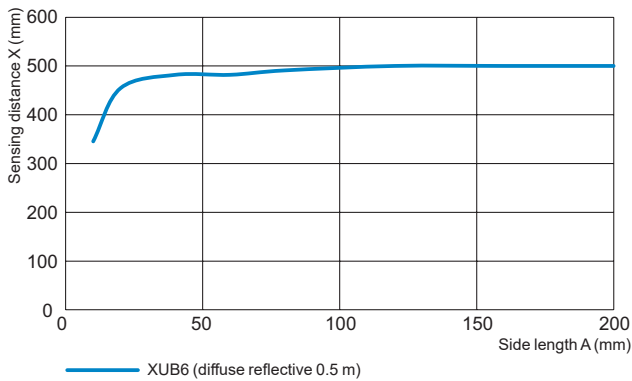

(1): Sensor
 (2): Object (white matt paper of A mm square)
 A: Side length (mm)
 X: Sensing distance (mm)

Lateral displacement. Line of sight: along case axis (axial)

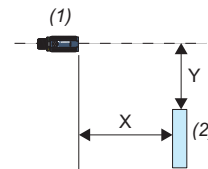
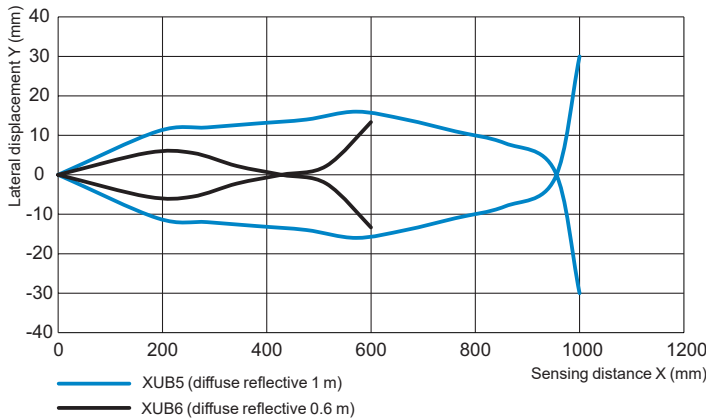

(1): Sensor
 (2): Object (200 mm square white paper)
 X: Sensing distance (mm)
 Y: Lateral displacement (mm)

Lateral displacement. Line of sight: 90° to case axis (radial)

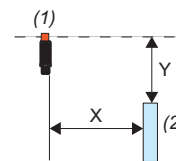
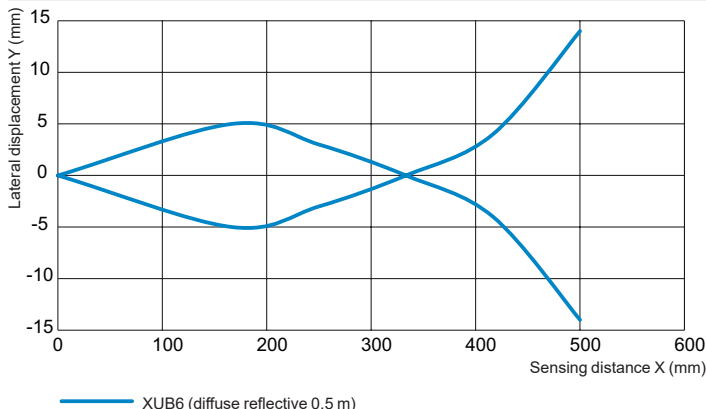

(1): Sensor
 (2): Object (200 mm square white paper)
 X: Sensing distance (mm)
 Y: Lateral displacement (mm)

Photo-electric sensors

XUB general purpose, single mode function

Cylindrical miniature design 18

Four-wire DC, solid-state output

Wire setting for NO/NC

Detection curves (continued)

Diffuse system: XUB5 and XUB6 (continued)

Excess gain. Line of sight: along case axis (axial)

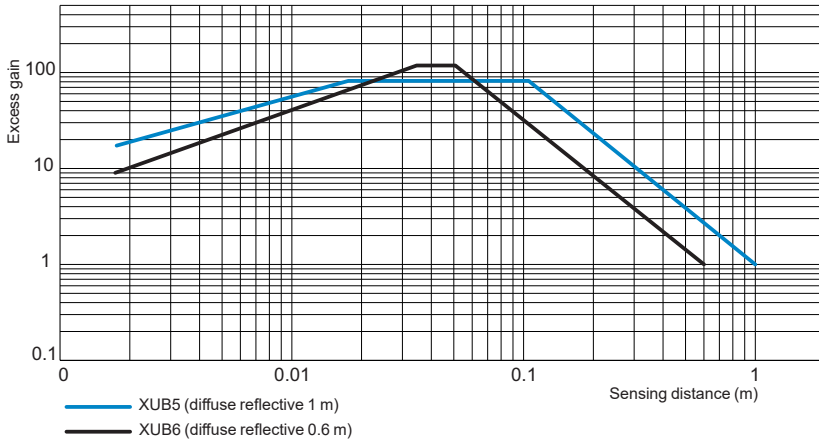

Excess gain. Line of sight: 90° to case axis (radial)

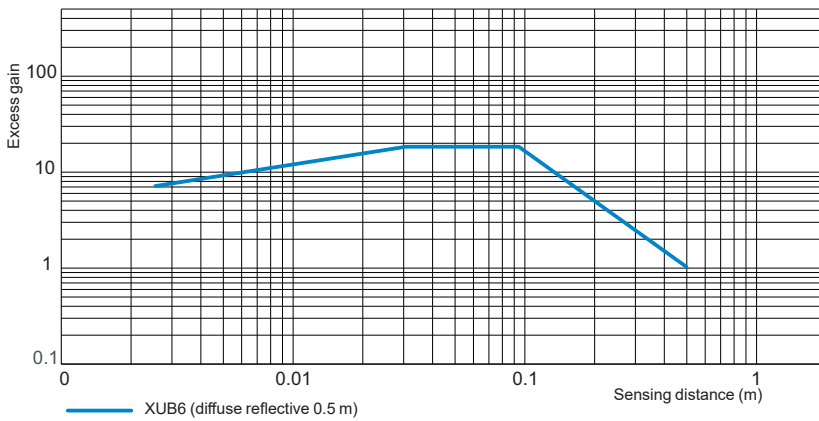

Polarised reflex system: XUB9

Reflector angle. Line of sight: along case axis (axial)

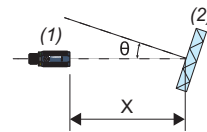
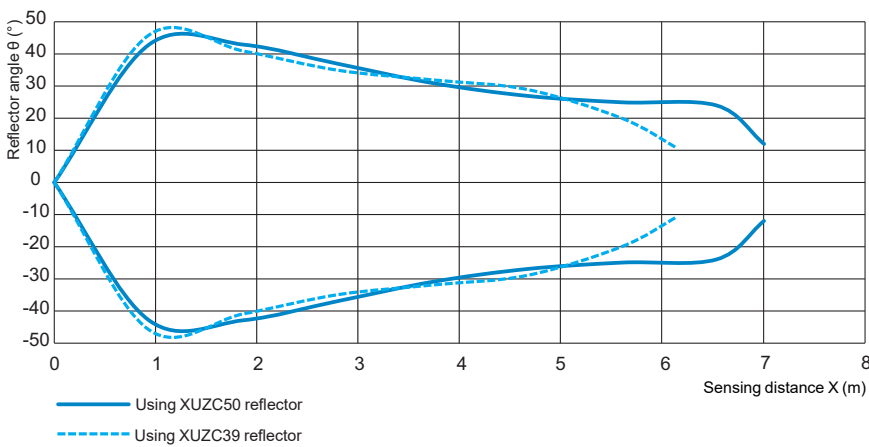

(1): Sensor
(2): Reflector
 θ : Reflector angle (°)
X: Sensing distance (m)

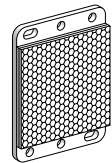

XUZC50



XUZC39

Photo-electric sensors

XUB general purpose, single mode function

Cylindrical miniature design 18

Four-wire DC, solid-state output

Wire setting for NO/NC

Detection curves (continued)

Polarised reflex system: XUB9 (continued)

Reflector angle. Line of sight: 90° to case axis (radial)

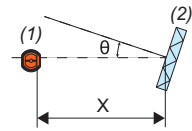
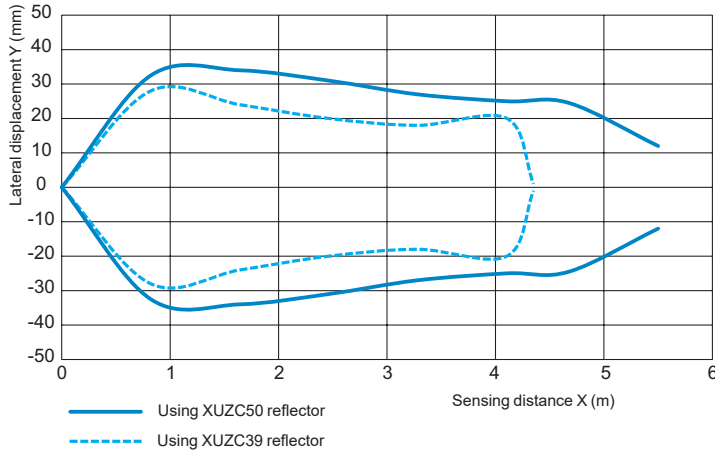

(1): Sensor
(2): Reflector
 θ : Reflector angle (°)
X: Sensing distance (m)

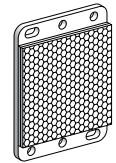

XUZC50



XUZC39

Lateral displacement. Line of sight: along case axis (axial)

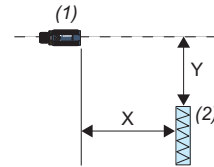
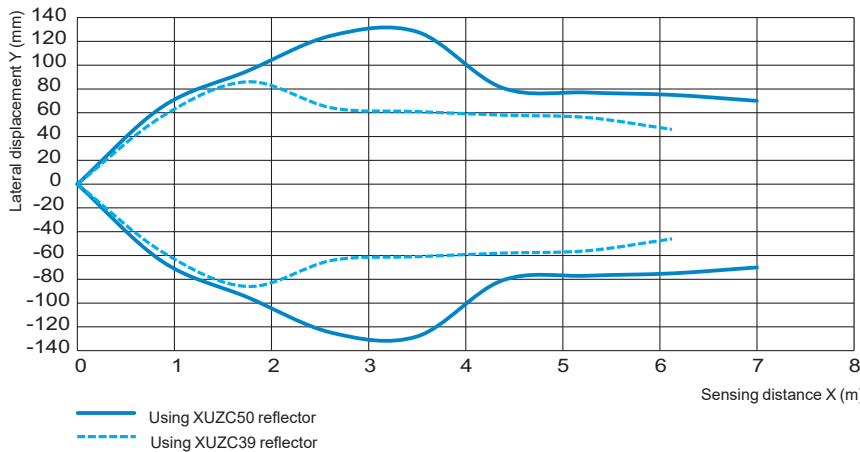

(1): Sensor
(2): Reflector
Y: Lateral displacement (mm)
X: Sensing distance (m)

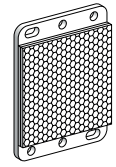

XUZC50



XUZC39

Lateral displacement. Line of sight: along case axis (axial)

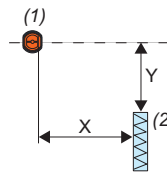
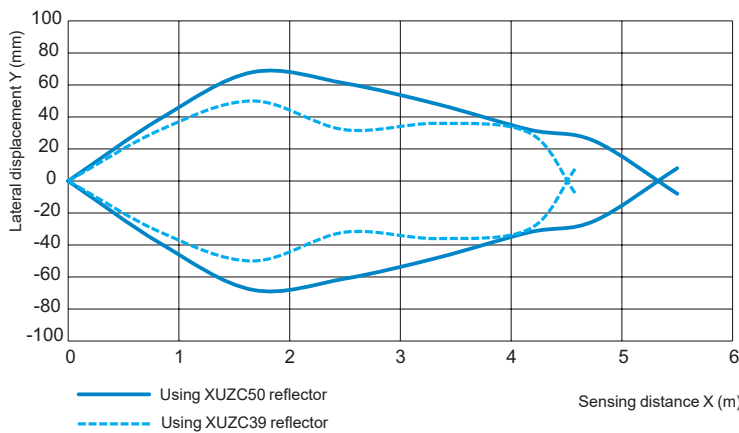

(1): Sensor
(2): Reflector
Y: Lateral displacement (mm)
X: Sensing distance (m)

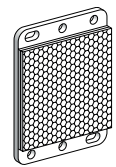

XUZC50



XUZC39

Photo-electric sensors

XUB general purpose, single mode function

Cylindrical miniature design 18, plastic

Four-wire DC, solid-state output

Wire setting for NO/NC

Detection curves (continued)

Polarised reflex system: XUB9 (continued)

Excess gain

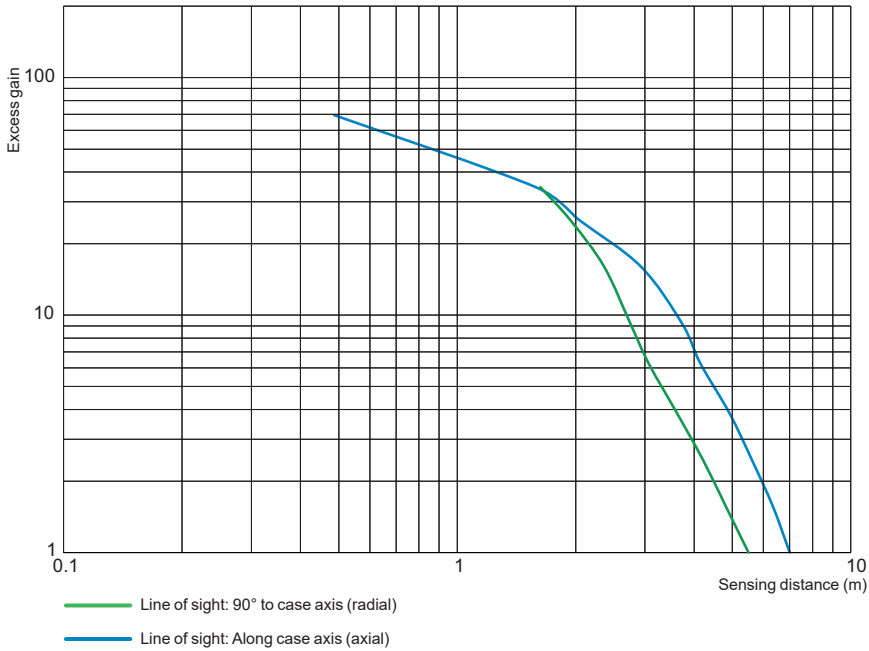

Photo-electric sensors

XUB general purpose, single mode function

Cylindrical miniature design 18, plastic

Four-wire DC, solid-state output

Wire setting for NO/NC

Thru-beam system, plastic, M12 connector version

Line of sight: along case axis (axial)

Kits Transmitter + Receiver: XUB2ANXNM12, XUB2APXNM12, XUB2APYNM12

Transmitter

XUB2AKXNM12T

Receiver

XUB2APYNM12R, XUB2ANXNM12R, XUB2APXNM12R

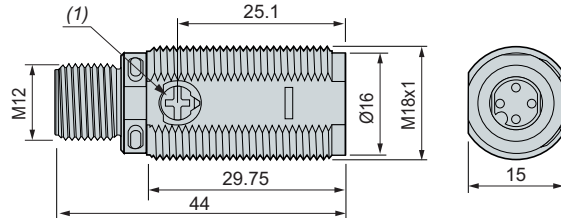
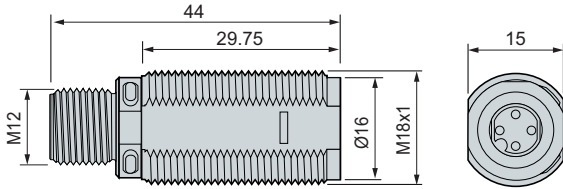

Line of sight: 90° to case axis (radial)

Kit Transmitter + Receiver: XUB2ANXWM12

Transmitter

XUB2AKXWM12T

Receiver

XUB2APYWM12R, XUB2ANXWM12R, XUB2APXWM12R

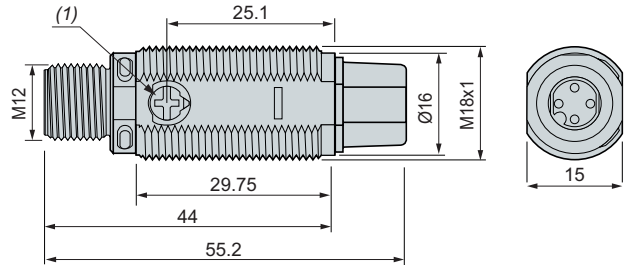
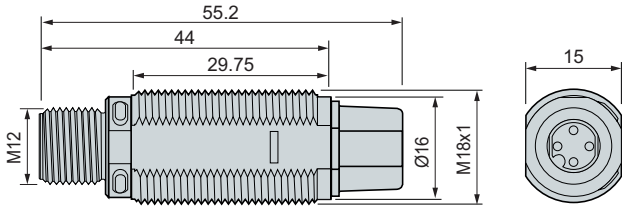

Thru-beam system, plastic, pre-cabled version

Line of sight: along case axis (axial)

Kit Transmitter + Receiver: XUB2ANXNL2, XUB2APXNL2

Transmitter

XUB2AKXNL2T

Receiver

XUB2ANXNL2R, XUB2APXNL2R

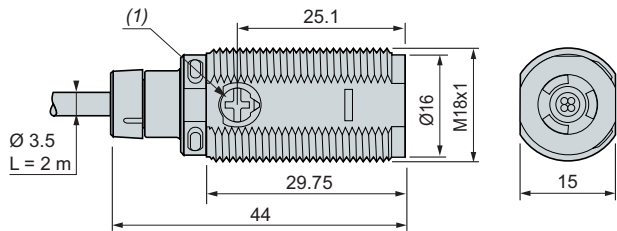
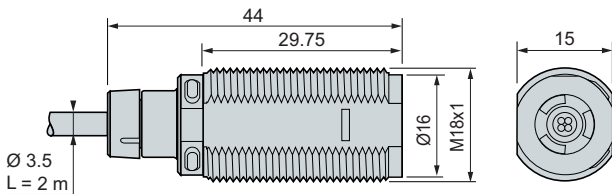

Pre-cabled version, line of sight 90° to case axis

Kits Transmitter + Receiver: XUB2APXWM12, XUB2APYWM12, XUB2ANXWL2, XUB2APXWL2

Transmitter

XUB2AKXWL2T

Receiver

XUB2ANXWL2R, XUB2APXWL2R

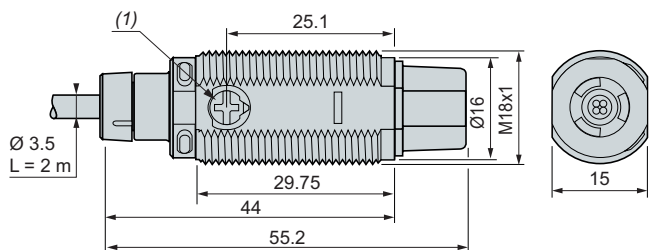
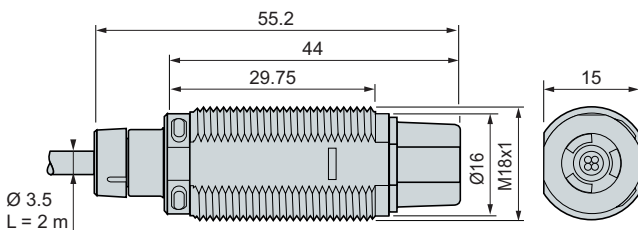

(1) Potentiomètre de réglage (sensibilité)

Photo-electric sensors

XUB general purpose, single mode function

Cylindrical miniature design 18, metal

Four-wire DC, solid-state output

Wire setting for NO/NC

Thru-beam system, metal, M12 connector version

Line of sight: along case axis (axial)

Kits Transmitter + Receiver: XUB2BPXNM12, XUB2BNXNM12, XUB2BPYNM12

Transmitter

XUB2BKXNM12T

Receiver

XUB2BPYNM12R, XUB2BNXNM12R, XUB2BPXNM12R

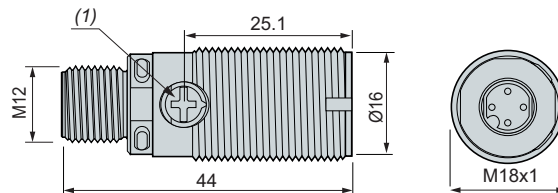
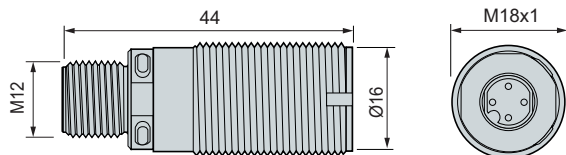

Line of sight: 90° to case axis (radial)

Kits Transmitter + Receiver: XUB2BNXWM12, XUB2BPYWM12, XUB2BPXWM12

Transmitter

XUB2BKXWM12T

Receiver

XUB2BPYWM12R, XUB2BNXWM12R, XUB2BPXWM12R

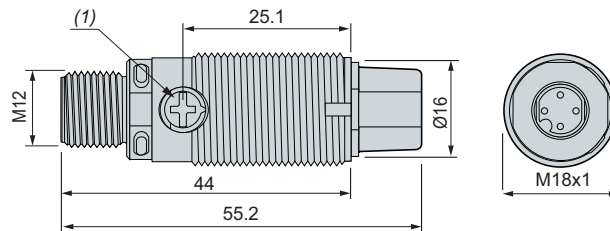
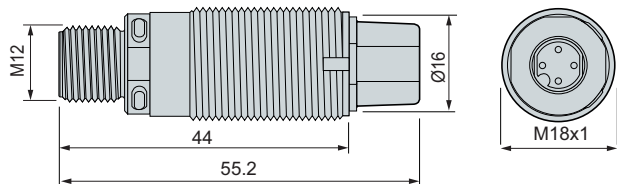

Thru-beam system, metal, pre-cabled version

Line of sight: along case axis (axial)

Kits Transmitter + Receiver: XUB2BNXNL2, XUB2BPXNL2

Transmitter

XUB2BKXNL2T

Receiver

XUB2BNXNL2R, XUB2BPXNL2R

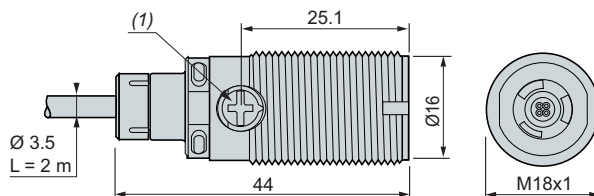
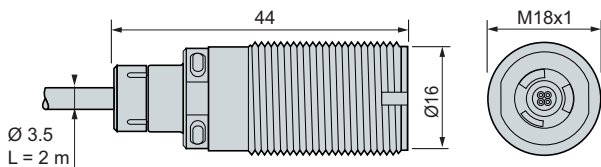

Pre-cabled version, line of sight 90° to case axis

Kits Transmitter + Receiver: XUB2BNXWL2, XUB2BPXWL2

Transmitter

XUB2BKXWL2T

Receiver

XUB2BNXWL2R, XUB2BPXWL2R

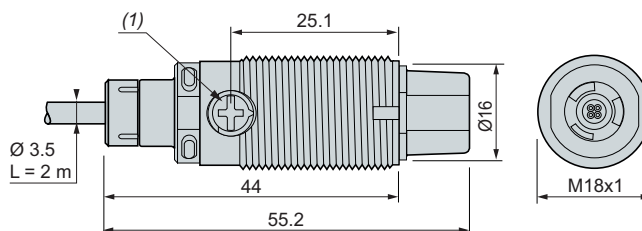
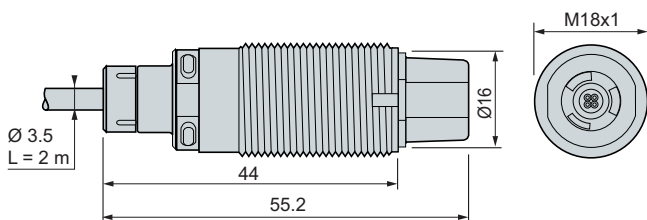

(1) Potentiomètre de réglage (sensibilité)

Photo-electric sensors

XUB general purpose, single mode function

Cylindrical miniature design 18

Four-wire DC, solid-state output

Wire setting for NO/NC

Diffuse system, plastic, M12 connector version

Line of sight: along case axis (axial)

XUB5ANXNM12, XUB6ANXNM12, XUB5APXNM12, XUB6APXNM12, XUB5APYNM12 and XUB6APYNM12

Line of sight: 90° to case axis (radial)

XUB6ANXWM12, XUB6APXWM12 and XUB6APYWM12

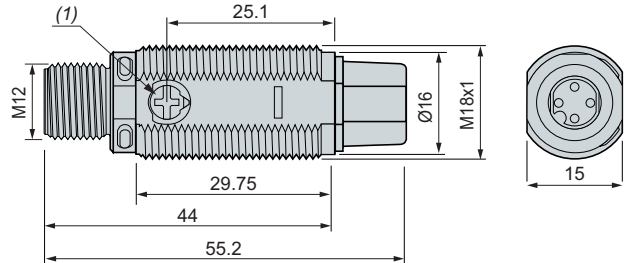
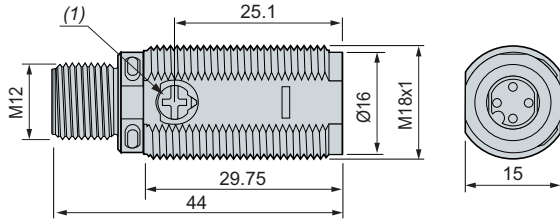

Diffuse system, plastic, pre-cabled version

Line of sight: along case axis (axial)

XUB5ANXL2, XUB6ANXL2, XUB5APXL2 and XUB6APXL2

Line of sight: 90° to case axis (radial)

XUB6ANXWL2 and XUB6APXL2

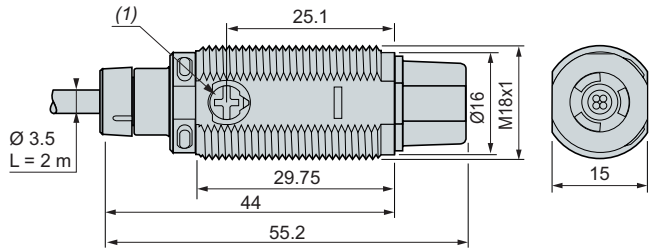
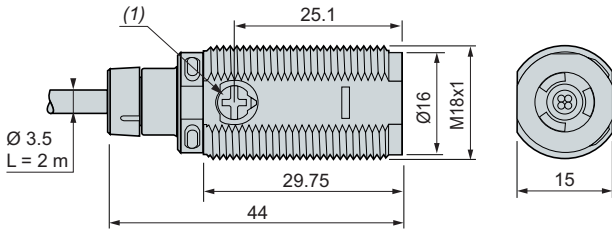

Diffuse system, metal, M12 connector version

Line of sight: along case axis (axial)

XUB5BNXNM12, XUB6BNXNM12, XUB5BPXNM12, XUB6BPXNM12, XUB5BPYNM12 and XUB6BPYNM12

Line of sight: 90° to case axis (radial)

XUB6BNXWM12, XUB6BPXWM12 and XUB6BPYWM12

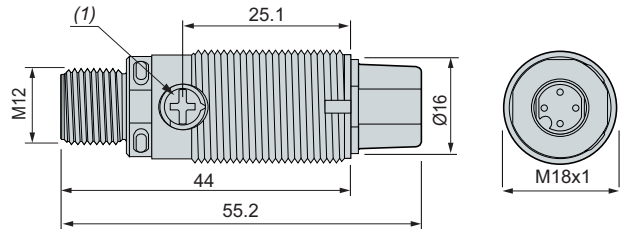
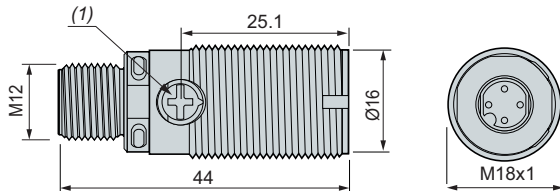

Diffuse system, metal, pre-cabled version

Line of sight: along case axis (axial)

XUB5BNXL2, XUB6BNXL2, XUB5BPXL2 and XUB6BPXL2

Line of sight: 90° to case axis (radial)

XUB6BNXWL2 and XUB6BPXL2

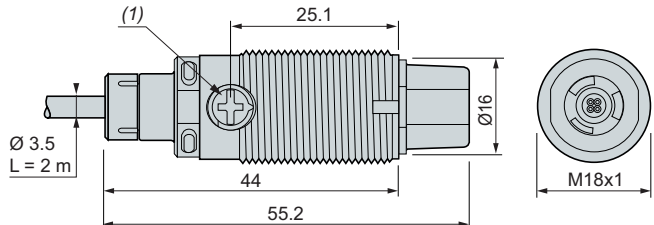
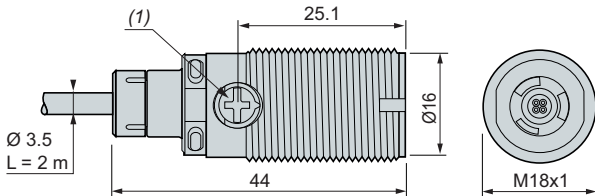

(1) Adjustment potentiometer (sensitivity).

Photo-electric sensors

XUB general purpose, single mode function

Cylindrical miniature design 18

Four-wire DC, solid-state output

Wire setting for NO/NC

Polarised reflex system, plastic, M12 connector version

Line of sight: along case axis (axial)

XUB9ANXNM12, XUB9APXNM12 and XUB9APYNM12

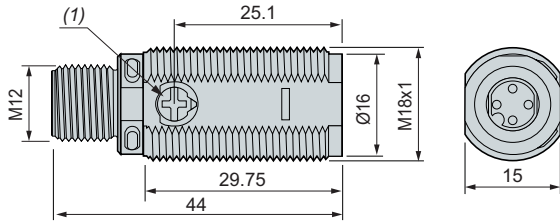

Line of sight: 90° to case axis (radial)

XUB9ANXWM12, XUB9APXWM12 and XUB9APYWM12

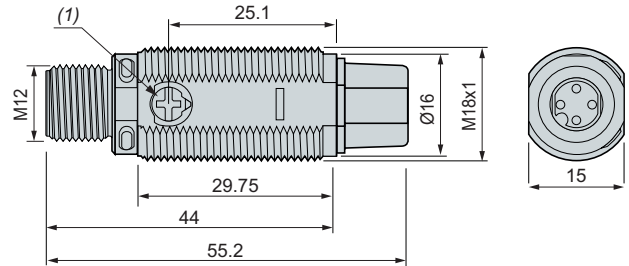

Polarised reflex system, plastic, pre-cabled version

Line of sight: along case axis (axial)

XUB9ANXNL2 and XUB9APXNL2

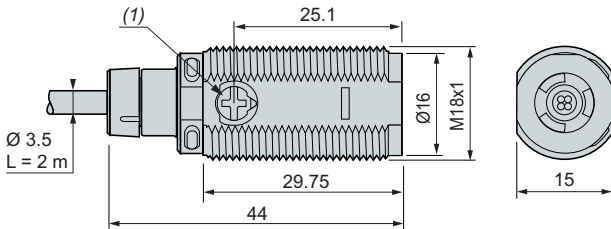

Line of sight: 90° to case axis (radial)

XUB9ANXWL2 and XUB9APXWL2

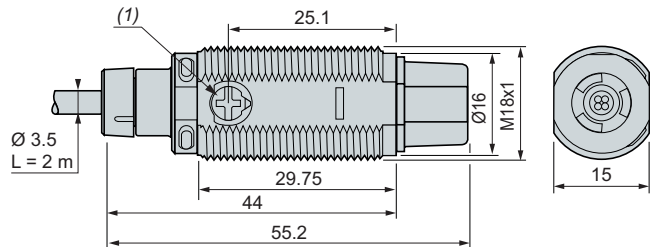

Polarised reflex system, metal, M12 connector version

Line of sight: along case axis (axial)

XUB9BNXNM12, XUB9BPXNM12 and XUB9BPNM12

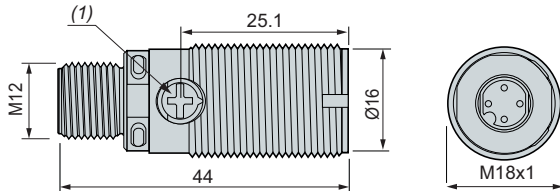

Line of sight: 90° to case axis (radial)

XUB9BNXWM12, XUB9BPXWM12 and XUB9BPYWM12

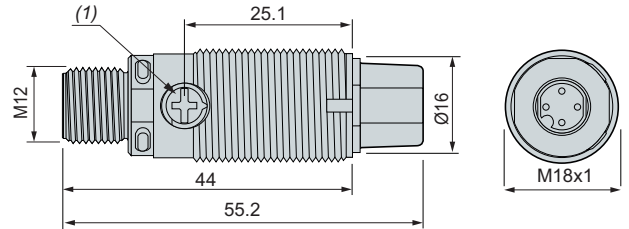

Polarised reflex system, metal, pre-cabled version

Line of sight: along case axis (axial)

XUB9BNXNL2 and XUB9BPXNL2

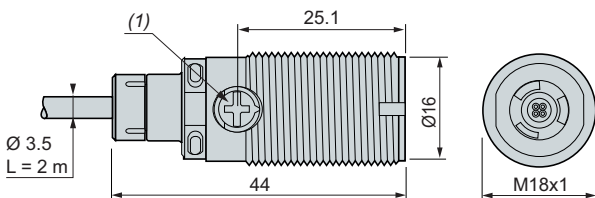

Line of sight: 90° to case axis (radial)

XUB9BNXWL2 and XUB9BPXWL2

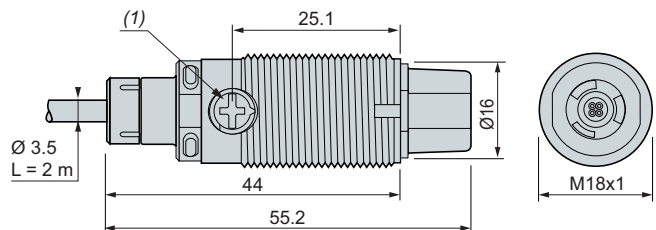

(1) Adjustment potentiometer (sensitivity).

Photo-electric sensors

XUN general purpose, single mode function

Hybrid miniature design, plastic, thru-beam system

Four-wire DC, solid-state output, wire setting for NO/NC

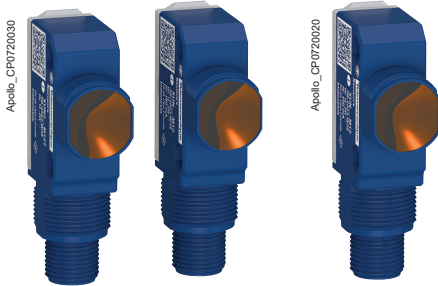

XUN2APYNM12



XUN2APYNM12R



XUN2ANXNL2
XUN2APXNL2



XUN2AKXNL2T



XUN2ANXNM12
XUN2APXNM12



XUN2AKXNM12T



XUN2ANXNL2R
XUN2APXNL2R



XUN2ANXNM12R
XUN2APXNM12R

Thru-beam system with adjustable sensitivity

Max./operating sensing distance (Sn)	Function	Output	Connection	Reference	Weight (kg)
--------------------------------------	----------	--------	------------	-----------	-------------

Transmitter + receiver IO-Link

30 m/20 m	NO/NC (Dark ON/Light ON) configuration by wire or IO-Link	Autodetect PNP/NPN	M12 connector (4-pin)	XUN2APYNM12	0.013
-----------	--	--------------------	-----------------------	--------------------	-------

Transmitter + receiver

30 m/20 m	NO/NC (Dark ON/Light ON) configuration by wire	NPN	Pre-cabled (L = 2 m)	XUN2ANXNL2	0.040
			M12 connector (4-pin)	XUN2ANXNM12	0.013
		PNP	Pre-cabled (L = 2 m)	XUN2APXNL2	0.040
			M12 connector (4-pin)	XUN2APXNM12	0.013

Transmitter only (1)

30 m/20 m			Pre-cabled (L = 2 m)	XUN2AKXNL2T	0.040
			M12 connector (4-pin)	XUN2AKXNM12T	0.013

Receiver IO-Link only

30 m/20 m	NO/NC (Dark ON/Light ON) configuration by wire or IO-Link	Autodetect PNP/NPN	M12 connector (4-pin)	XUN2APYNM12R	0.013
-----------	--	--------------------	-----------------------	---------------------	-------

Receiver

30 m/20 m	NO/NC (Dark ON/Light ON) configuration by wire	NPN	Pre-cabled (L = 2 m)	XUN2ANXNL2R	0.040
			M12 connector (4-pin)	XUN2ANXNM12R	0.013
		PNP	Pre-cabled (L = 2 m)	XUN2APXNL2R	0.040
			M12 connector (4-pin)	XUN2APXNM12R	0.013

Accessories

IO-Link Master

See page 78.

Fixing and other accessories

See page 82.

Cabling accessories

See page 88.

(1) All transmitters are compatible with the receivers listed below.

Photo-electric sensors

XUN general purpose, single mode function

Hybrid miniature design, plastic, thru-beam system

Four-wire DC, solid-state output, wire setting for NO/NC



XUN5APYNM12
XUN6APYNM12



XUN5ANXNL2
XUN5APXNL2



XUN5ANXNM12
XUN5APXNM12



XUN6ANXNL2
XUN6APXNL2



XUN6ANXNM12
XUN6APXNM12

Diffuse system with adjustable sensitivity IO-Link

Max./operating sensing distance (Sn)	Function	Output	Connection	Reference	Weight (kg)
--------------------------------------	----------	--------	------------	-----------	-------------

Long range, red LED emission

1 m/0.7 m	NO/NC (Light ON/Dark ON) configuration by wire or IO-Link	Autodetect PNP/NPN	M12 connector (4-pin)	XUN5APYNM12	0.013
-----------	--	--------------------	-----------------------	--------------------	-------

Medium range, red LED emission

0.6 m/0.42 m	NO/NC (Light ON/Dark ON) configuration by wire or IO-Link	Autodetect PNP/NPN	M12 connector (4-pin)	XUN6APYNM12	0.013
--------------	--	--------------------	-----------------------	--------------------	-------

Diffuse system with adjustable sensitivity

Max./operating sensing distance (Sn)	Function	Output	Connection	Reference	Weight (kg)
--------------------------------------	----------	--------	------------	-----------	-------------

Long range, red LED emission

1 m/0.7 m	NO/NC (Light ON/Dark ON) configuration by wire	NPN	Pre-cabled (L = 2 m)	XUN5ANXNL2	0.040
			M12 connector (4-pin)	XUN5ANXNM12	0.013
		PNP	Pre-cabled (L = 2 m)	XUN5APXNL2	0.040
			M12 connector (4-pin)	XUN5APXNM12	0.013

Medium range, red LED emission

0.6 m/0.42 m	NO/NC (Light ON/Dark ON) configuration by wire	NPN	Pre-cabled (L = 2 m)	XUN6ANXNL2	0.040
			M12 connector (4-pin)	XUN6ANXNM12	0.013
		PNP	Pre-cabled (L = 2 m)	XUN6APXNL2	0.040
			M12 connector (4-pin)	XUN6APXNM12	0.013

Accessories

IO-Link Master

See page 78.

Fixing and other accessories

See page 82.

Cabling accessories

See page 88.

Photo-electric sensors

XUN general purpose, single mode function
 Hybrid miniature design, plastic, polarised reflex system
 Four-wire DC, solid-state output, wire setting for NO/NC



XUN9APYNM12



XUN9ANXNL2
 XUN9APXNL2



XUN9ANXNM12
 XUN9APXNM12

Polarised reflex system with adjustable sensitivity, IO-Link

Plastic, red LED emission

Max./operating sensing distance (Sn)	Function	Output	Connection	Reference	Weight (kg)
7 m/5 m	NO/NC (Dark ON/Light ON) configuration by wire or IO-Link	Autodetect PNP/NPN	M12 connector (4-pin)	XUN9APYNM12	0.013

Polarised reflex system with adjustable sensitivity

Plastic, red LED emission

Max./operating sensing distance (Sn)	Function	Output	Connection	Reference	Weight (kg)
7 m/5 m	NO/NC (Dark ON/Light ON) configuration by wire	NPN	Pre-cabled (L = 2 m)	XUN9ANXNL2	0.040
			M12 connector (4-pin)	XUN9ANXNM12	0.013
7 m/5 m	NO/NC (Dark ON/Light ON) configuration by wire	PNP	Pre-cabled (L = 2 m)	XUN9APXNL2	0.040
			M12 connector (4-pin)	XUN9APXNM12	0.013

Accessories

IO-Link Master

See page 78.

Fixing and other accessories

See page 82.

Cabling accessories

See page 88.

Characteristics			
Sensor type			XUN2APYNM12, XUN2APYNM12R, XUN2A●XNM12, XU2AKXNM12T, XUN2A●XNM12R, XUN5APYNM12, XUN5A●XNM12, XUN6APYNM12, XUN6A●XNM12, XUN9APYNM12, XUN9A●XNM12
Product certifications			CE, UKCA, cULus
Connection	Connector		M12
	Pre-cabled		–
Sensing distance	Thru-beam system XUN2	m	30 (with excess gain = 1) 20 (with excess gain = 2)
	Diffuse system XUN5 (using a white paper 200 x 200 mm)	m	1 (with excess gain = 1) 0.7 (with excess gain = 2)
	Diffuse system XUN6 (using a white paper 200 x 200 mm)	m	0.6 (with excess gain = 1) 0.42 (with excess gain = 2)
	Polarised reflex system XUN9 (using a 50 x 50 mm reflector XUZC50)	m	7 (with excess gain = 1) 5 (with excess gain = 2)
Blind zone		mm	0 (white object and potentiometer max.)
Sensing distance setting			Potentiometer 1 turn (+/- 220 degrees)
Colour of detection light beam			Red
Output type			PNP/NPN (or autodetect PNP/NPN with IO-Link)
Hysteresis			2 % < H < 20 % at Sn
Degree of protection	Conforming to IEC 60529		IP65, IP67
	Conforming to DIN 40050-9		IP69K (M12 connector versions only)
Artificial optical radiation	Conforming to IEC 62471		Class 0 (risk exempt)
Radiated disturbances emissions	Conforming to EN 55011/CISPR 1		Class A
Storage temperature		°C	-40...+70
Operating temperature		°C	-30...+55
Materials	Case		PBT/PC
	Lens cover		PMMA
	Transparent cover		ABS
	Potentiometer screw		PA66
	Cable		–
Vibration resistance	Conforming to IEC 60068-2-6		Frequency range: 10 to 55 Hz Acceleration: 7 gn
Shock resistance	Conforming to IEC 60068-2-27		Peak acceleration: 30 gn Duration of the pulse: 11 ms
Rated supply voltage		V	12...24 --- with protection against reverse polarity
Voltage limits (including ripple)		V	10...30 ---
Current consumption, no-load		mA	< 20/IO-Link: < 30
Switching capacity		mA	100
Voltage drop, closed state		V	< 2 max.
Maximum switching frequency		Hz	1000
Delays	First-up	ms	< 100/IO-Link : < 300
	Response	ms	0.5 max.
	Recovery	ms	0.5 max

Photo-electric sensors

XUN general purpose, single mode function

Hybrid miniature design, plastic, thru-beam and diffuse systems

Four-wire DC, solid-state output, wire setting for NO/NC

Wiring schemes

Thru-beam system

M12 connector - 4 pins - IO-Link

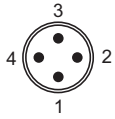

Pin	Signal	Definition
1	+	+ 24 V $\overline{\text{DC}}$
2	IN	+ = NO - = NC Open = NO
3	-	0 V $\overline{\text{DC}}$
4	Q	Switching signal (SIO)
	C	IO-Link communication

Autodetect PNP/NPN or by IO-Link

XUN2APYNM12

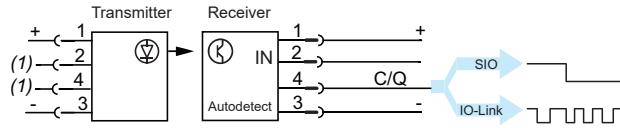

Note: IODD IO-Link files available on our website www.telemecaniquesensors.com/iolink

M12 connector - 4 pins

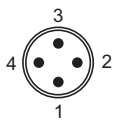

Pin	Signal	Definition
1	+	+ 24 V $\overline{\text{DC}}$
2	IN	+ = NO - = NC Open = NO
3	-	0 V $\overline{\text{DC}}$
4	Q	Switching signal (SIO)

PNP

XUN2APXNM12

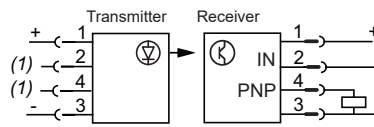

NPN

XUN2ANXNM12

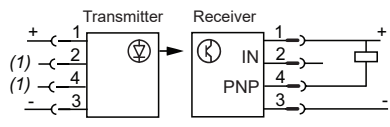

Pre-cabled - 4 wires

+BN (Brown)
IN (input) GY (Grey)
OUT (output) BK (Black)
-BU (Blue)

PNP

XUN2APXNL2

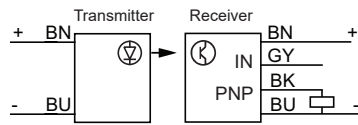

NPN

XUN2ANXNL2

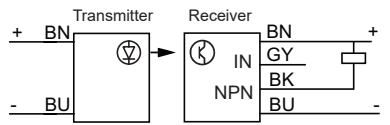

Diffuse system

M12 connector - 4 pins - IO-Link

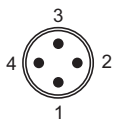

Pin	Signal	Definition
1	+	+ 24 V $\overline{\text{DC}}$
2	IN	+ = NO - = NC Open = NO
3	-	0 V $\overline{\text{DC}}$
4	Q	Switching signal (SIO)
	C	IO-Link communication

Autodetect PNP/NPN or by IO-Link

XUN5APYNM12, XUN6APYNM12

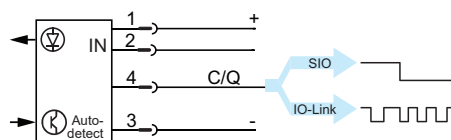

Note: IODD IO-Link files available on our website www.telemecaniquesensors.com/iolink

M12 connector - 4 pins

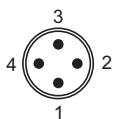

Pin	Signal	Definition
1	+	+ 24 V $\overline{\text{DC}}$
2	IN	+ = NO - = NC Open = NO
3	-	0 V $\overline{\text{DC}}$
4	Q	Switching signal (SIO)

PNP

XUN5APXNM12, XUN6APXNM12

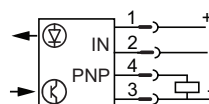

NPN

XUN5ANXNM12, XUN6ANXNM12

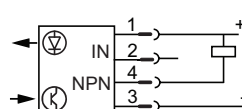

(1) Not connected

Photo-electric sensors

XUN general purpose, single mode function
 Hybrid miniature design, plastic, diffuse and polarised
 reflex systems
 Four-wire DC, solid-state output, wire setting for NO/NC

Wiring schemes (continued)

Diffuse system (continued)

Pre-cabled - 4 wires

+BN (Brown)
 IN (input) GY (Grey)
 OUT (output) BK (Black)
 -BU (Blue)

PNP

XUN5APXNL2, XUN6APXNL2

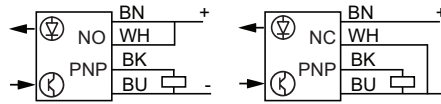

NPN

XUN5ANXNL12, XUN6ANXNL2

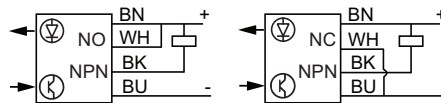

Polarised reflex system

M12 connector - 4 pins - IO-Link

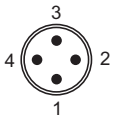

Pin	Signal	Definition
1	+	+ 24 V
2	IN	+ = NO - = NC Open = NO
3	-	0 V
4	Q	Switching signal (SIO)
C		IO-Link communication

Autodetect PNP/NPN or by IO-Link

XUN9APYNM12

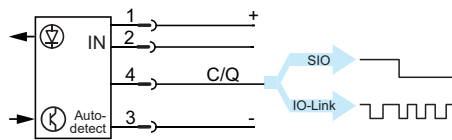

Note: IO-Link files available on our website www.telemecaniquesensors.com/iolink

M12 connector - 4 pins

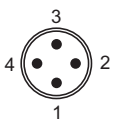

Control input IN:
 (+) = NO
 (-) = NC
 Open = NO

PNP

XUN9APXNM12

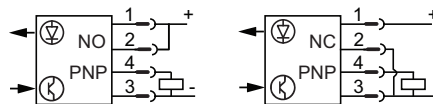

NPN

XUN9ANXNM12

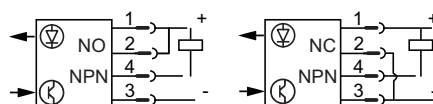

Pre-cabled - 4 wires

+BN (Brown)
 IN (input) GY (Grey)
 OUT (output) BK (Black)
 -BU (Blue)

PNP

XUN9APXNL2

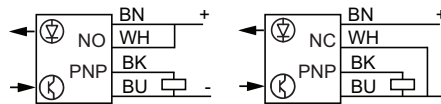

NPN

XUN9ANXNL12

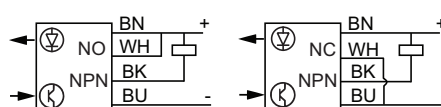

Photo-electric sensors

XUN general purpose, single mode function

Hybrid miniature design, plastic, thru-beam system

Four-wire DC, solid-state output, wire setting for NO/NC

Detection curves

Thru-beam system: XUN2

Lateral displacement

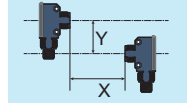
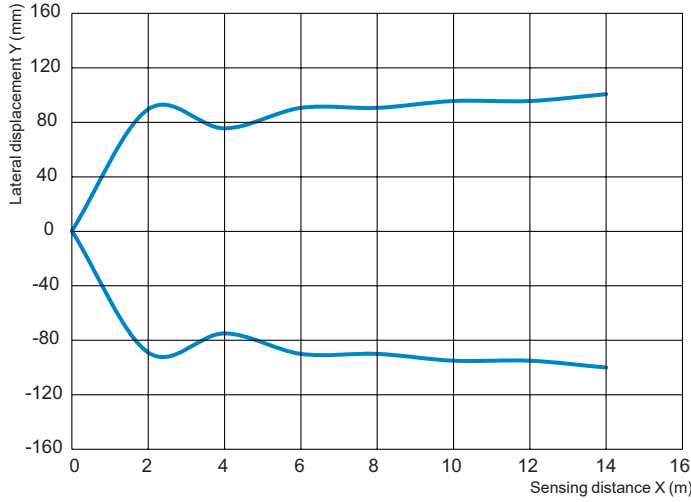

Light beam diameter

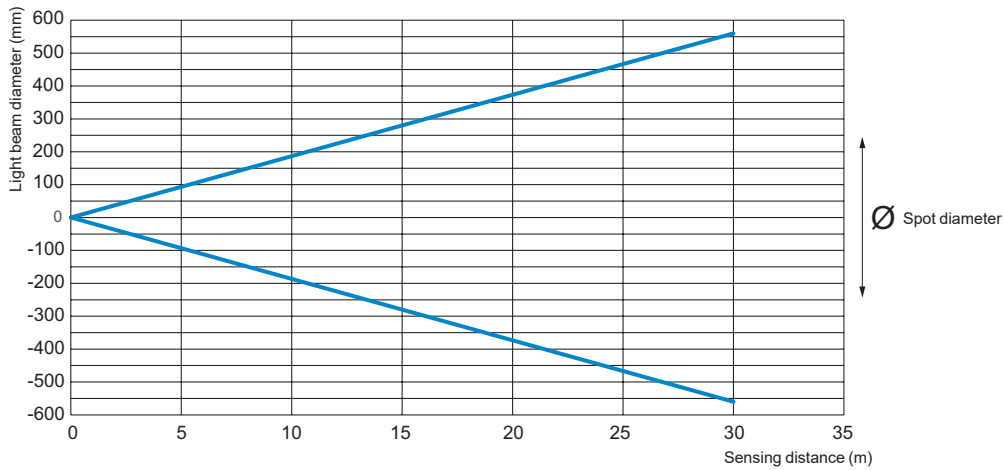

Excess gain

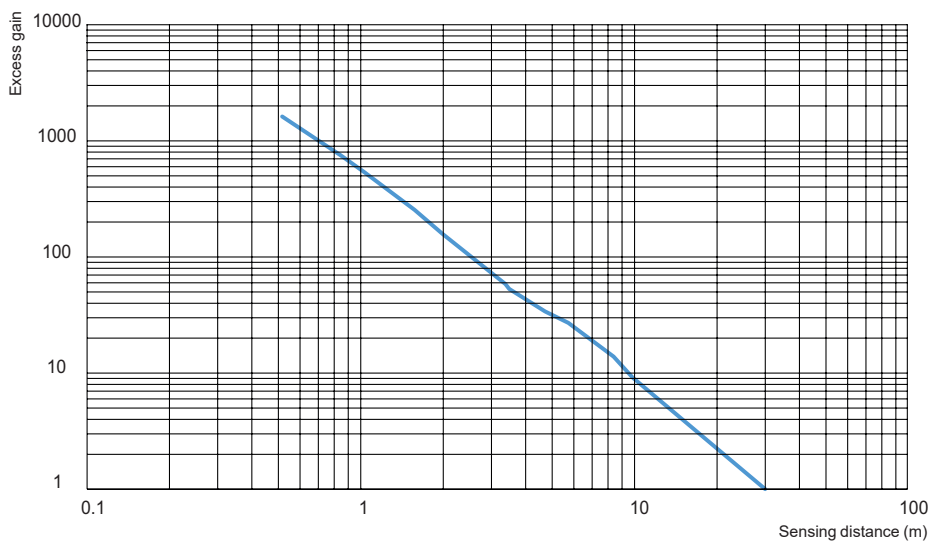

Photo-electric sensors

XUN general purpose, single mode function

Hybrid miniature design, plastic, diffuse system

Four-wire DC, solid-state output, wire setting for NO/NC

Detection curves (continued)

Diffuse system: XUN5 and XUN6

Minimum object size/sensing distance

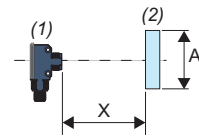
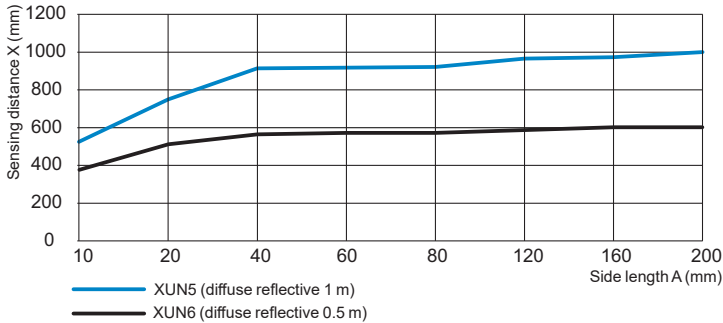

(1): Sensor
 (2): Object (white matt paper of A mm square)
 A: Side length (mm)
 X: Sensing distance (mm)

Lateral displacement

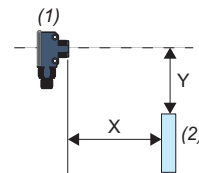
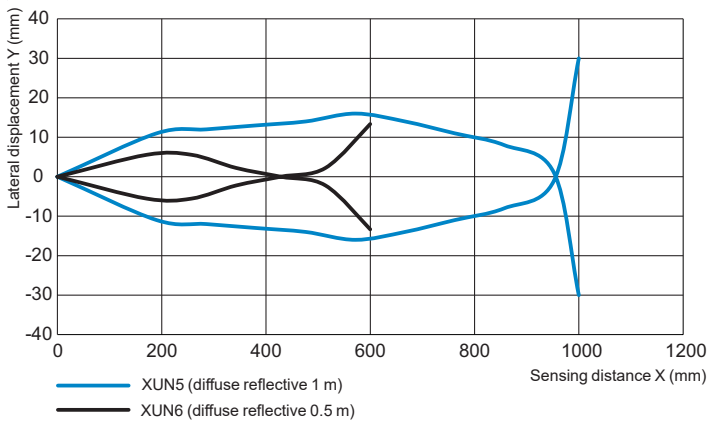

(1): Sensor
 (2): Object (200 mm square white paper)
 X: Sensing distance (mm)
 Y: Lateral displacement (mm)

Excess gain

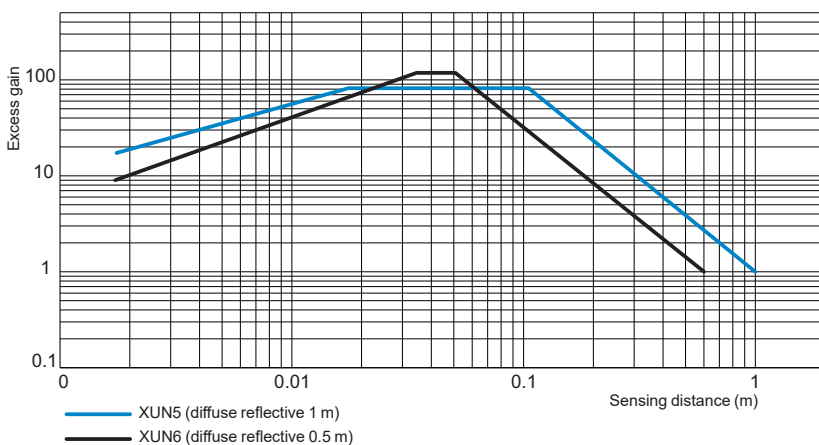

Photo-electric sensors

XUN general purpose, single mode function
 Hybrid miniature design, plastic, polarised reflex system
 Four-wire DC, solid-state output, wire setting for NO/NC

Detection curves (continued)

Polarised reflex system: XUN9

Reflector angle

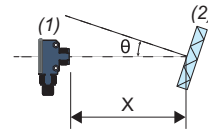
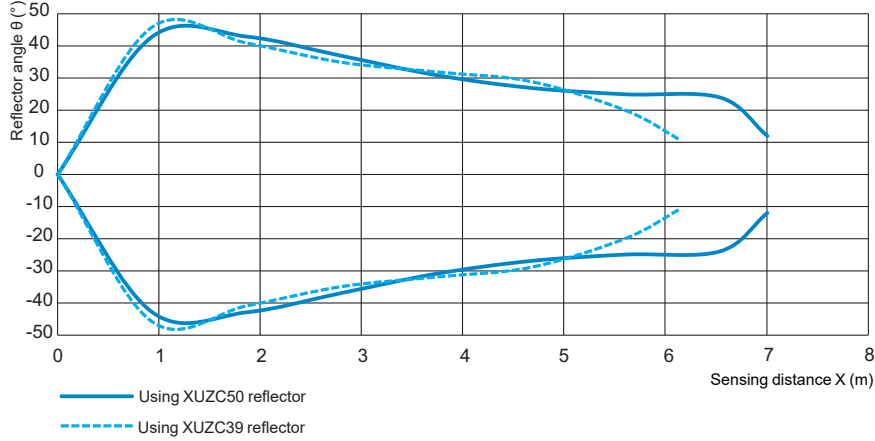

(1): Sensor
 (2): Reflector
 θ : Reflector angle (°)
 X: Sensing distance (m)

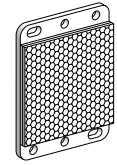

XUZH50



XUZH39

Lateral displacement

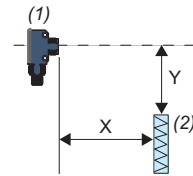
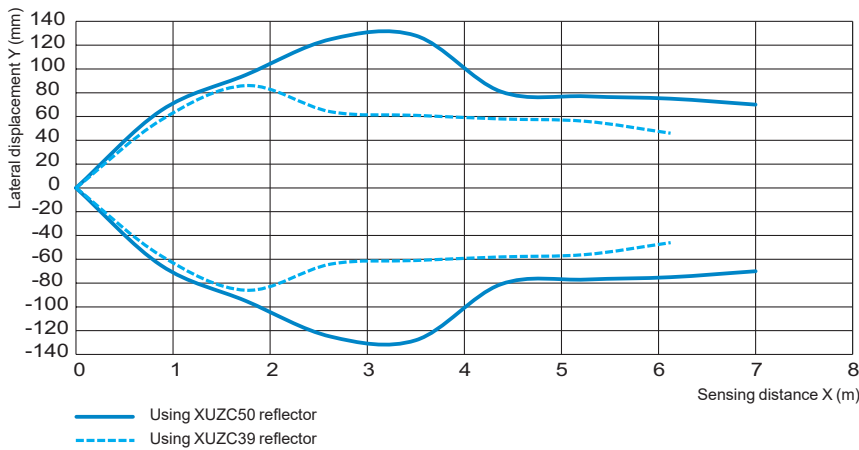

(1): Sensor
 (2): Reflector
 Y: Lateral displacement (mm)
 X: Sensing distance (m)

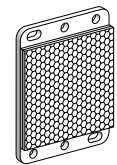

XUZH50



XUZH39

Excess gain

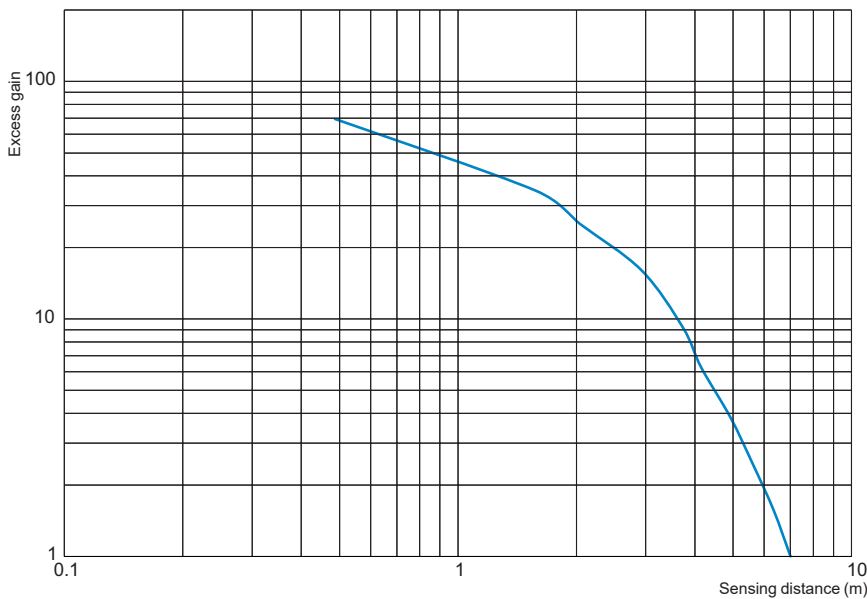

Photo-electric sensors

XUN general purpose, single mode function

Hybrid miniature design, plastic, thru-beam system

Four-wire DC, solid-state output, wire setting for NO/NC

Thru-beam system, plastic, M12 connector version

Transmitter + receiver (common top, side and front views)

XUN2APYNM12, XUN2ANXNM12, XUN2APXNM12

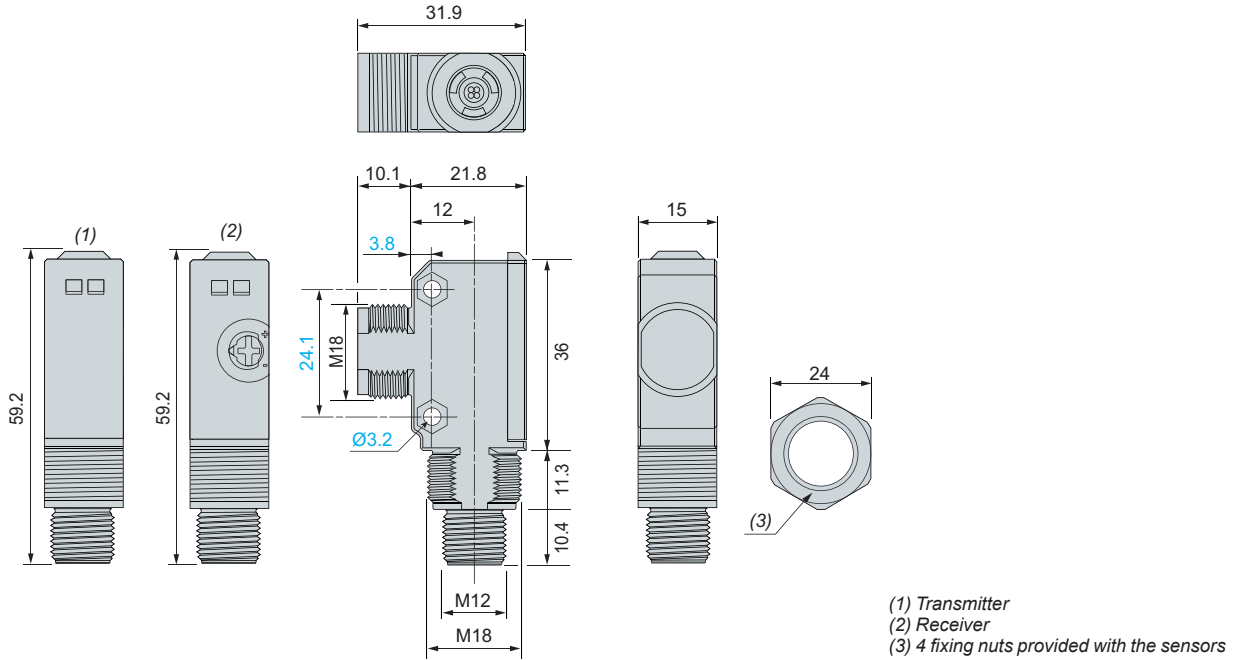

Transmitter only

XUN2AKXNM12T

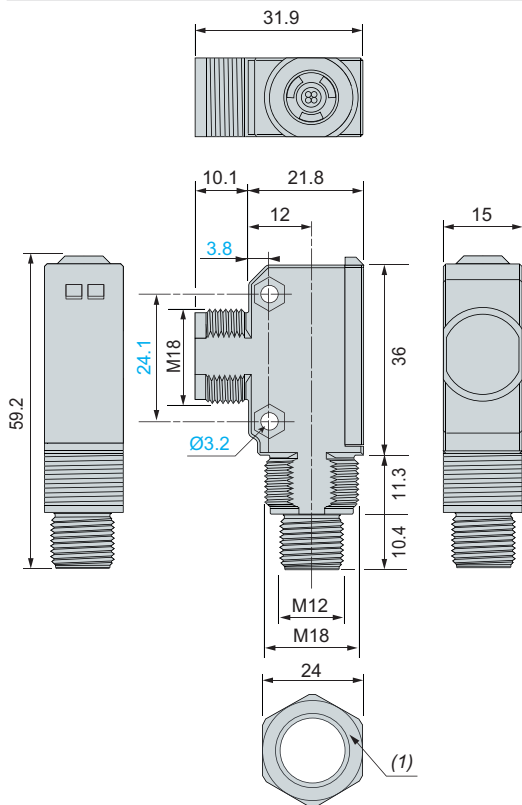

Receiver only

XUN2APYNM12R, XUN2ANXNM12R, XUN2APXNM12R

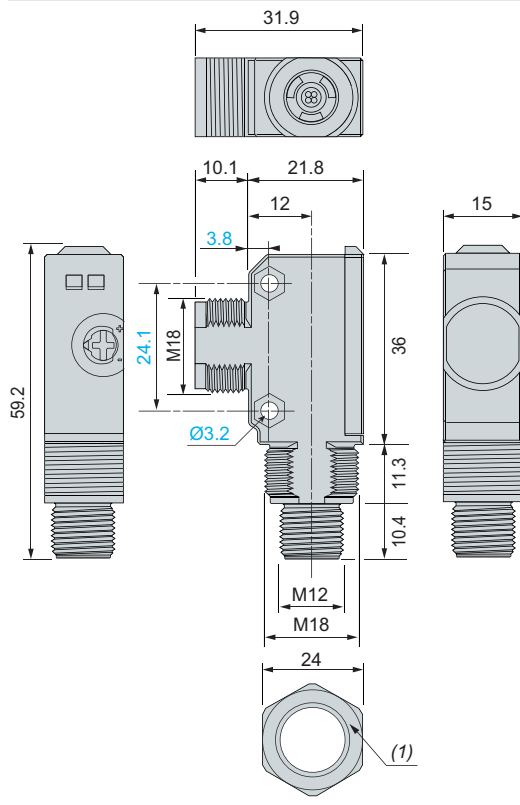

(1) 2 fixing nuts provided with the sensor.

Photo-electric sensors

XUN general purpose, single mode function

Hybrid miniature design, plastic, thru-beam system

Four-wire DC, solid-state output, wire setting for NO/NC

Thru-beam system, plastic, pre-cabled version

Transmitter + receiver (common top, side and front views)

XUN2ANXNL2, XUN2APXNL2

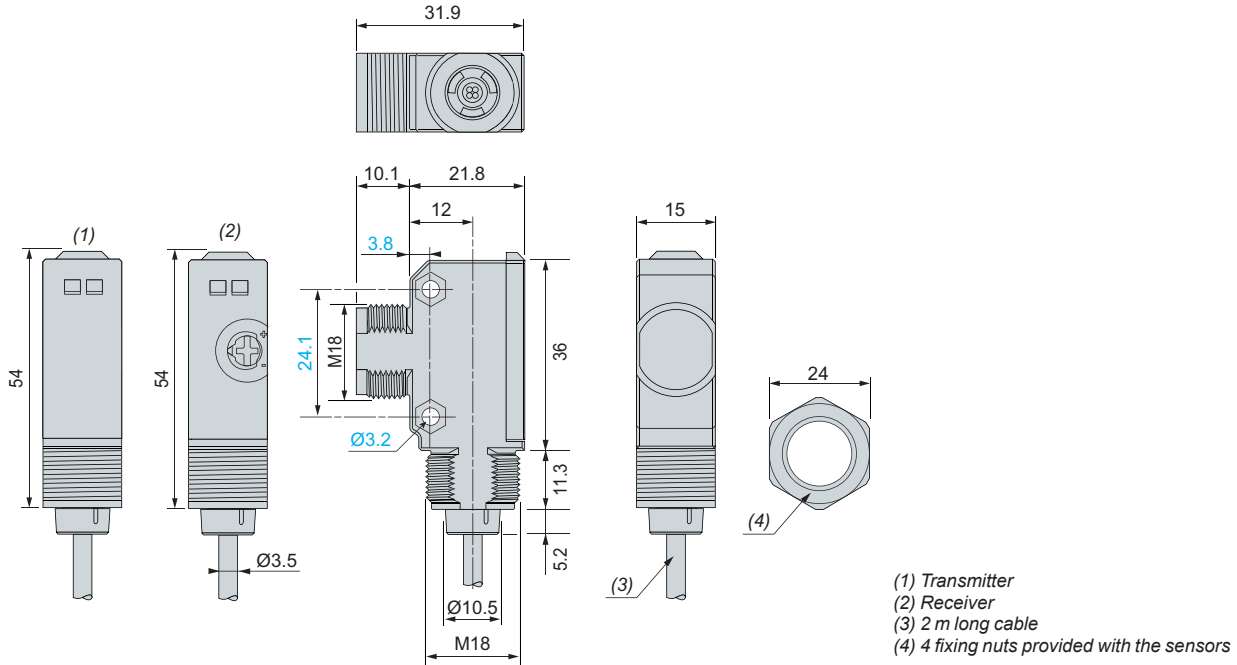

Transmitter only

XUN2AKXNL2T

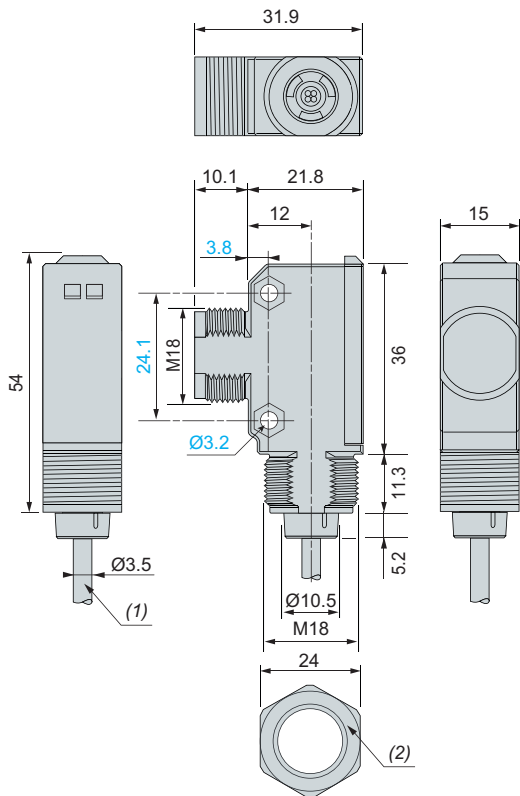

Receiver only

XUN2ANXNL2R, XUN2APXNL2R

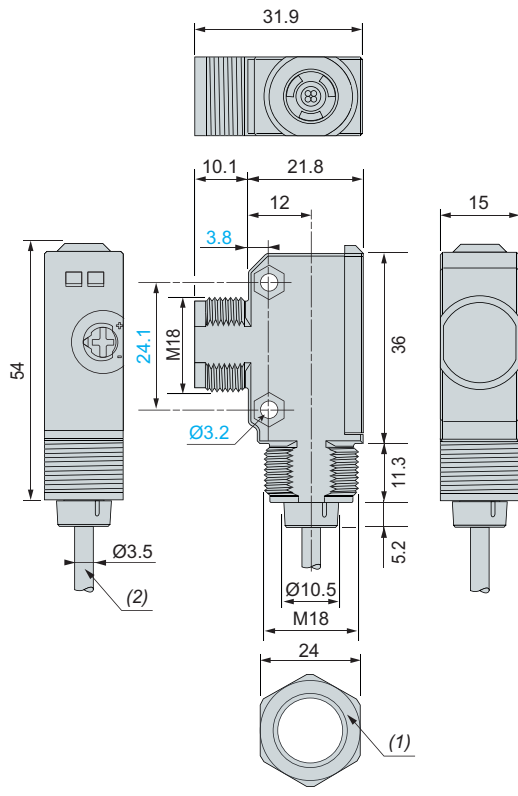

(1) 2 m long cable.
 (2) 2 fixing nuts provided with the sensor.

Photo-electric sensors

XUN general purpose, single mode function
Hybrid miniature design, plastic, diffuse and polarised
reflex systems

Four-wire DC, solid-state output, wire setting for NO/NC

Diffuse system, M12 connector version

Long range or medium range, red LED emission

XUN5APYNM12, XUN5ANXNM12, XUN5APXNM12,
XUN6APYNM12, XUN6ANXNM12, XUN6APXNM12

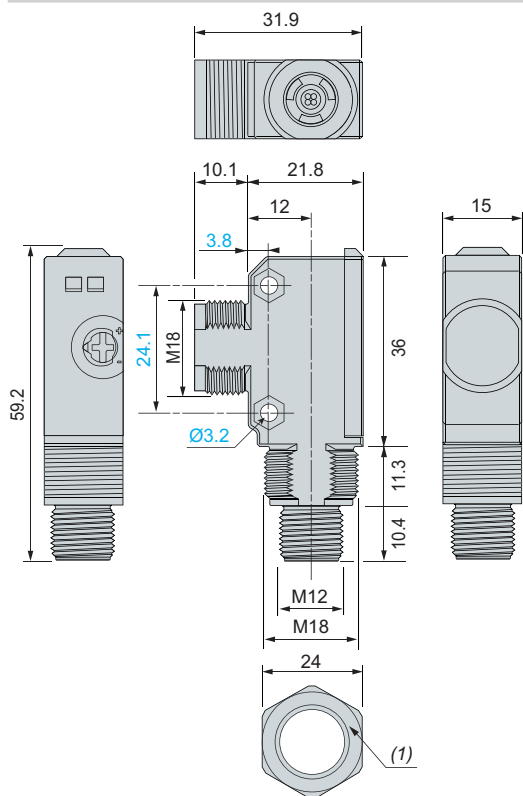

Diffuse system, pre-cabled version

Long range or medium range, red LED emission

XUN5ANXNL2, XUN5APXNL2, XUN6ANXNL2, XUN6APXNL2

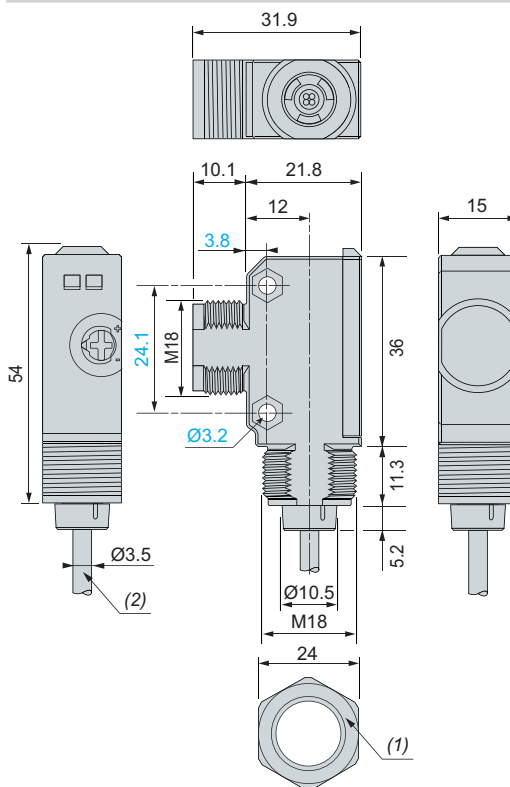

Polarised reflex system, M12 connector version

XUN9APYNM12, XUN9ANXNM12, XUN9APXNM12

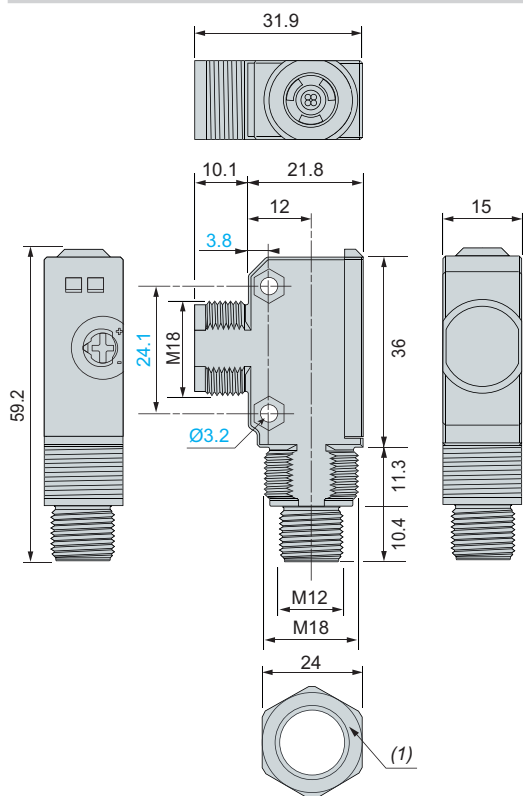

Polarised reflex system, pre-cabled version

XUN9ANXNL2, XUN9APXNL2

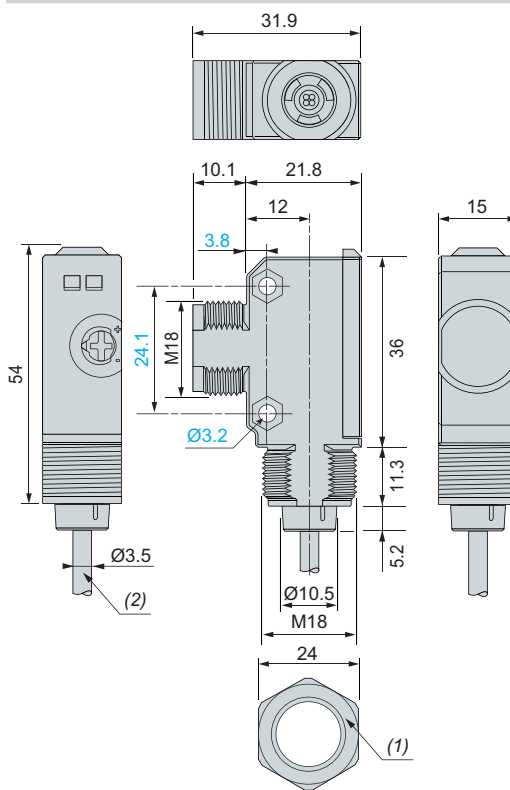

(1) 2 fixing nuts provided with the sensor.
(2) 2 m long cable.



XU photo-electric sensors
for packaging, food & beverage

Telemecanique Sensors presents an expanded XU range of application photo-electric sensors to be embedded in automated lines for the packaging market segment.

With their diverse technical characteristics, high performance and smart management capabilities, they are designed to address a wide scope of specific needs.



Packaging



Handling



Food and Beverage

Fast object detection

Sensor family per application

- > Marking detection
- > Very dark object detection
- > Accurate detection
- > Colour object detection, from simple colour to very complex colour sorting



Read the promotional video



Five detection types

Select the perfectly suitable light spot

- > **Blue light**: for low-reflectivity objects, especially dark ones. Blue light short waves mean less penetration, resulting in higher surface reflection.
- > **Red light**: for detecting objects at a long distance and/or transparent objects
- > **Laser light**: to detect very small objects and contrast marks with pinpoint accuracy, even at a long sensing distance
- > **White light**: for simple contrast detection (high contrast), short distances
- > **RGB light**: for more accurate contrast in colour prints



Blue light



Red light



Laser



White light



RGB

Designed for small spaces in packaging machines

Choose the casing, connection type and size

- > Plastic or metal (1) casing
- > Pre-cabled, with pigtail or connector
- > Compact, miniature, and sub-miniature size

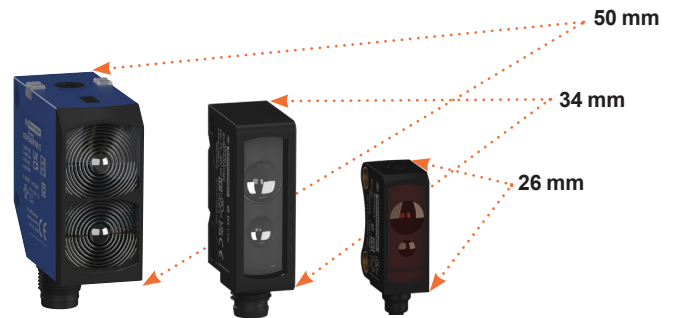

Simple communication with the PLC via Ethernet

Smart devices communicate via IO-Link protocol

- > Install your new IO-Link sensor easily: automatic reading of the device identification file (IODD) and automatic detection of the sensor output mode
- > Automated parameter settings: configure the detection parameters
- > Extended diagnostics, with real-time information for optimised usage and maintenance

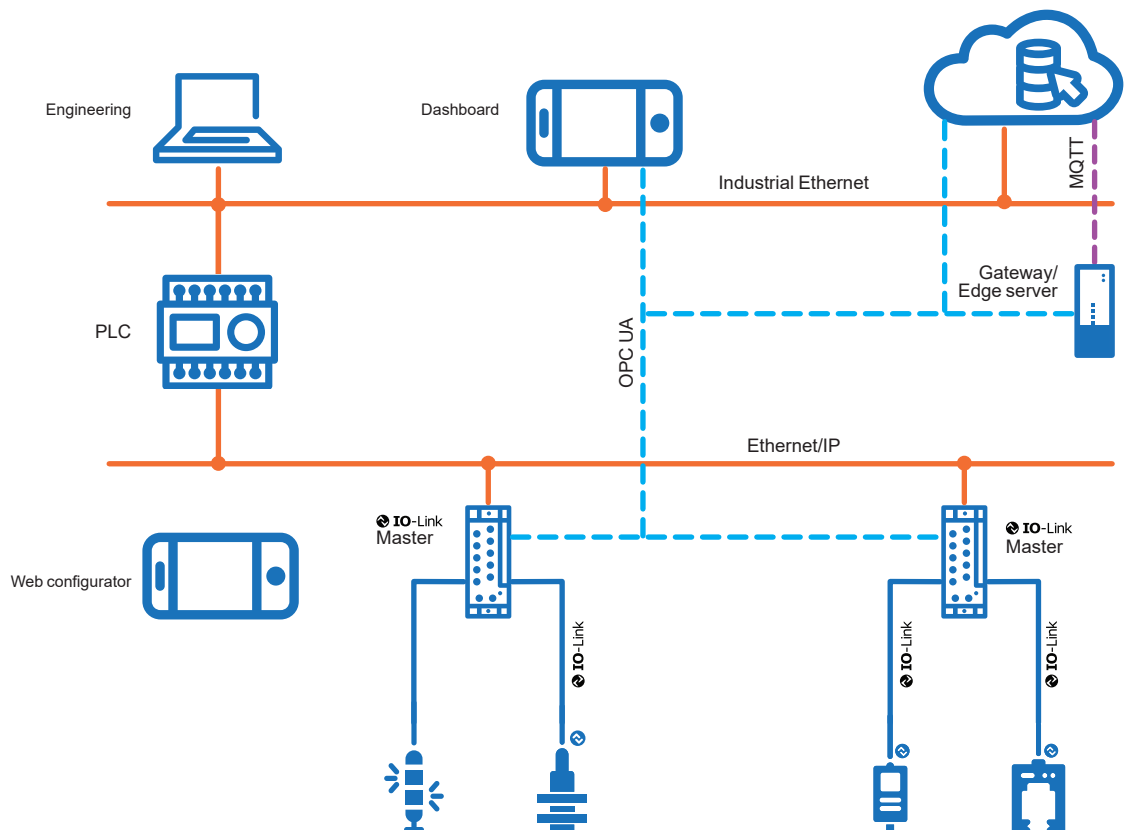
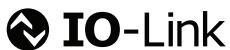

(1) XUKC only has a metal casing.

Photo-electric sensors

XU range application

Contrast system for marking detection

Miniature design, plastic



XUMRAWAYM8
XUMRAGAYM8
XUMRACAYM8



XUMRAWAYP015
XUMRAGAYP015



XUMRPGAYM8



XUM5ALAYM8



XUM5ALAYL2

Contrast mark reader sensors IO-Link

Max./operating sensing distance (Sn)	Function	Output	Connection	Reference	Weight (kg)
White light					
15 mm/12 mm	NO/NC configuration via teach-in or IO-Link	Autodetect PNP/NPN	M8 connector (4-pin)	XUMRAWAYM8	0.018
		Autodetect PNP/NPN	Pigtail M12 (L= 0.15 m)	XUMRAWAYP015	0.027

RGB light

15 mm/12 mm	NO/NC configuration via Teach-in or IO-Link	Autodetect PNP/NPN	M8 connector (4-pin)	XUMRAGAYM8	0.018
		Autodetect PNP/NPN	M8 connector (4-pin)	XUMRACAYM8	0.018
		Autodetect PNP/NPN	Pigtail M12 (L= 0.15 m)	XUMRAGAYP015	0.027
		Autodetect PNP/NPN	M8 connector (4-pin)	XUMRPGAYM8	0.01

Laser light

250 mm/150 mm	NO/NC configuration via Teach-in or IO-Link	Autodetect PNP/NPN	Pre-cabled (L = 2 m)	XUM5ALAYL2	0.045
		Autodetect PNP/NPN	M8 connector (4-pin)	XUM5ALAYM8	0.018
		Autodetect PNP/NPN	Pigtail M12 (L= 0.15 m)	XUM5ALAYP015	0.026

Accessories

IO-Link Master

See page 78.

Fixing and other accessories

See page 82.

Cabling accessories

See page 88.

Characteristics				XUMRA●AY●●	XUMRPGAYM8	XUM5ALAY●●
Sensor type				CE, UKCA, cULus, Ecolab	CE, UKCA, cULus	CE, UKCA, cULus, Ecolab
Product certifications						
Connection	Connector		M8	M8	M8	
	Pigtail	Connector	M12	–	M12	
		Length	m	0.15	–	0.15
	Pre-cabled	Length	–	–	2	
Maximum sensing distance S _{max}	Contrast mark reader	mm	15	15	250	
Detection light beam colour				White LED RGB (red, green, blue)	RGB (red, green, blue)	Red (laser class 1)
Degree of protection	Conforming to IEC 60529		IP67			
	Conforming to DIN 40050-9		IP69K	IP67	IP69K	
Storage temperature		°C	-20...+80	-40...+70	-20...+80	
Operating temperature		°C	-20...+55	-25...+55	-20...+60	
Materials	Case		ABS	Glass-filled technopolymer	ABS	
	Lens		PMMA			
	Front		PMMA	PMMA	PMMA	
	Cable		PVC	–	PVC	
Rated supply voltage		V	12...24 ---			
Voltage limits (including ripple)		V	10...30 ---			
Current consumption, no-load		mA	≤ 30 for RGB ≤ 25 for white light	≤ 40 (≤ 20 at 24V)	≤ 30	
Switching capacity		mA	100	≤ 100	100	
Maximum switching frequency	XUMRAWAY●●	Hz	10,000	–	–	
	XUMRAGAY●●	Hz	10,000	–	–	
	XUMRACAY●●	Hz	2500	–	–	
	XUMRPGAYM8	Hz	–	30,000 (selectable by IO-Link) 60,000 (by default)	–	
	XUM5ALAY●●	Hz	–	–	4000	
Delays	First-up	ms	300	0.08	300	
	Response	XUMRAWAY●●	µs	50	–	–
		XUMRAGAY●●	µs	50	–	–
		XUMRACAY●●	µs	200	–	–
		XUMRPGAYM8	µs	–	16	–
		XUM5ALAY●●	µs	–	–	125
	Recovery	ms	300	–	300	
IO-Link	ms	> 230				

Photo-electric sensors

XU range application

Constrast system for marking detection

Miniature design, plastic

Wiring schemes

Contrast mark reader systems

M8 and M12 connectors – 4-pin – IO-Link

Pin	Signal	Definition
1	+	+ 24 V $\overline{\text{---}}$
2	IN	+ = NO - = NC Open = NO
3	-	0 V $\overline{\text{---}}$
4	Q	Switching signal (SIO)
	C	Communication (IO-Link)

Autodetect PNP/NPN or by IO-Link

XUM●A●AYM8 XUM●A●AYP015 (white, RGB, and laser)

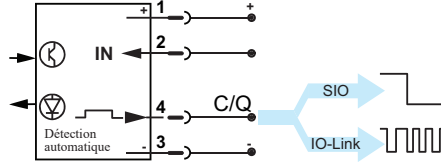

Note : IODD IO-Link files are available on our web site www.telemecaniquesensors.com/iolink

Pre-cabled – 4-wire – IO-Link

Pin	Signal	Definition
1	+	+ 24 V $\overline{\text{---}}$
2	IN	+ = NO - = NC Open = NO
3	-	0 V $\overline{\text{---}}$
4	C	Switching signal (SIO) Communication (IO-Link)

Autodetect PNP/NPN or by IO-Link

XUM5ALAYL2 (laser)

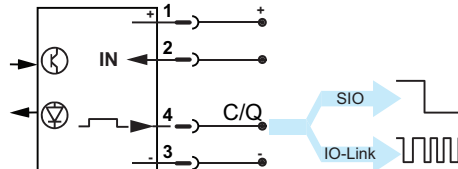

Note : IODD IO-Link files are available on our web site www.telemecaniquesensors.com/iolink

M8 connector – 4-wire – IO-Link

Pin	Signal	Definition
1	+	+ 24 V $\overline{\text{---}}$
2	IN (1)	Teach-in L/D (NO/NC) Delay enable
3	-	0 V $\overline{\text{---}}$
4	Q	Switching signal (SIO)
	C	Communication (IO-Link)

PNP, potentiometer or by IO-Link

XUMRPGAYM8

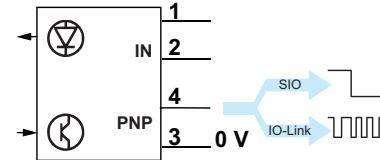

Note : IODD IO-Link files are available on our web site www.telemecaniquesensors.com/iolink

(1) By default, pin 2 is configured as push-pull OUTPUT; it can be configured as INPUT with IO-Link.

Detection curves

Contrast mark reader: XUMRA●AYM8, XUMRA●AYP015, XUMRPGAYM8

Signal process

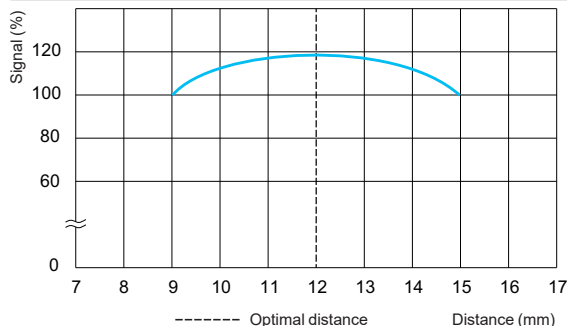

Contrast mark reader: XUM5ALAY●●

Light spot size

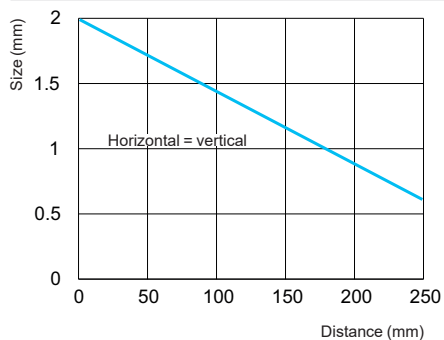

Excess gain

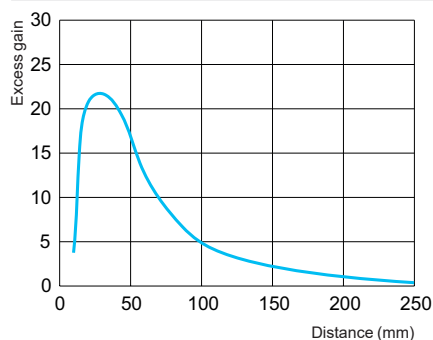

Dimensions

Miniature format: XUM

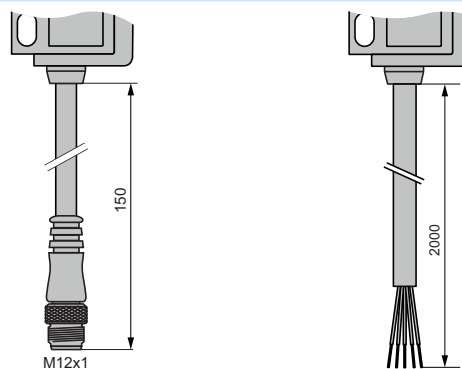
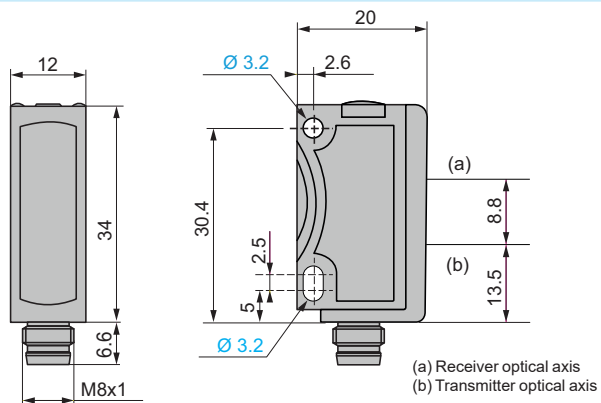

Miniature format: XUMRPGAYM8

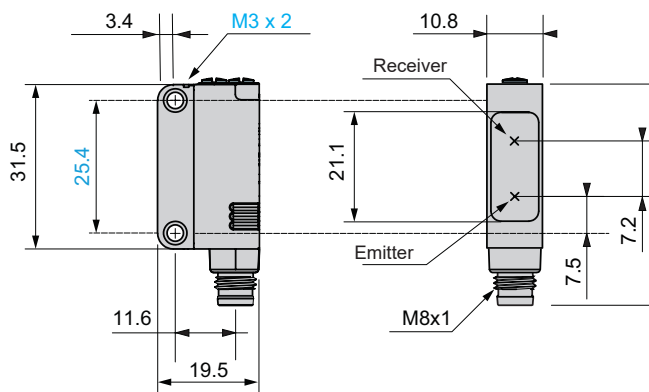

Photo-electric sensors

XU range application

Blue light sensors for very dark object detection

Compact, miniature, and sub-miniature design, plastic



XUM8ABAYP015



XUM7ABPXL2



XUM7ABPXM8,
XUM8ABAYM8



XUT7ABPXL2,
XUT8ABAYL2



XUT7ABPXP02,
XUT8ABAYP02



XUK8ABPXM12



Read the promotional video



Background suppression sensors IO-Link

Max./operating sensing distance (Sn)	Function	Output	Connection	Reference	Weight (kg)
Adjustable blue light					
200 mm/200 mm miniature format	NO/NC configuration via teach-in or IO-Link	Autodetect PNP/NPN	M8 connector (4-pin)	XUM8ABAYM8	0.014
		Autodetect PNP/NPN	Pigtail M12 (L= 0.15 m)	XUM8ABAYP015	0.027
100 mm/100 mm sub-miniature format	NO/NC configuration via teach-in or IO-Link	Autodetect PNP/NPN	Pre-cabled (L = 2 m)	XUT8ABAYL2	0.031
		Autodetect PNP/NPN	Pigtail M8 (L= 0.2 m)	XUT8ABAYP02	0.019

Background suppression sensors

Fixed blue light, miniature format

100 mm/80 mm	NO/NC configuration via teach-in or IO-Link	PNP	Pre-cabled (L = 2 m)	XUM7ABPXL2	0.056
		PNP	M8 connector (4-pin)	XUM7ABPXM8	0.017

Fixed blue light, sub-miniature format

50 mm/50 mm	NO/NC configuration via teach-in or IO-Link	PNP	Pre-cabled (L = 2 m)	XUT7ABPXL2	0.031
		PNP	Pigtail M8 (L= 0.2 m)	XUT7ABPXP02	0.022

Adjustable blue light (potentiometer)

1200 mm/600 mm	NO/NC configuration via teach-in or IO-Link	PNP	M12 connector (4-pin)	XUK8ABPXM12	0.046
----------------	---	-----	-----------------------	--------------------	-------

Accessories

IO-Link Master

See page 78.

Fixing and other accessories

See page 82.

Cabling accessories

See page 88.

Characteristics				XU●7ABPX●●	XU●8ABAY●●	XUK8ABPXM12	
Sensor type				XU●7ABPX●●	XU●8ABAY●●	XUK8ABPXM12	
Product certifications				CE, UKCA, cULus, Ecolab			
Connection	Connector			M8	M8	M12	
	Pre-cabled	Length	m	2	2	–	
	Pigtail	Length XUM8	m	0.2	0.15	–	
XUT8			m		0.2		
Maximum sensing distance Smax	BGS, fixed blue light	XUM7	mm	100	–	–	
		XUT7	mm	50	–	–	
	BGS, adjustable blue light	XUM8	mm	–	200	–	
		XUT8	mm	–	100	–	
		XUK8	mm	–	–	1200	
Detection light beam colour				Blue			
Degree of protection	Conforming to IEC 60529			IP67			
	Conforming to DIN 40050-9			IP69K for XUM7 only	IP69K for XUM8 only	IP69K	
Storage temperature				°C	-20...+80		
Operating temperature	XUM7		°C	-20...+60	-20...+60		
	XUT7		°C	-20...+50			
Materials	Case	XUM		ABS	ABS	ABS/PC	
		XUT		PUR	PUR		
	Lens			PMMA			
	Front			PMMA			
	Cable			PVC			
Rated supply voltage	XUM8	V	12...24 ---	12...24	12...24 ---		
	XUT8	V		24 ---			
Voltage limits (including ripple)				V	10...30	10...30	10...30
Current consumption, no-load	XUM		mA	≤ 30			
	XUT		mA	≤ 20			
Switching capacity	XUM		mA	≤ 100			
	XUT		mA	≤ 50			
Maximum switching frequency				Hz	1000	700	600
Delays	First-up		ms	< 300			
	Response	XUM	µs	500	500	830 max.	
		XUT	µs		700		
	Recovery		ms	< 300			
IO-Link		ms	> 230				

Photo-electric sensors

XU range application

Blue light sensors for very dark object detection

Compact, miniature, and sub-miniature design, plastic

Wiring schemes

Background suppression sensor

M8 connector (including pigtail) - 4-pin



Pin	Signal	Definition
1	+	+ 24 V $\overline{\text{---}}$
2	IN	+ = NC - = NO Open = NO
3	-	0 V $\overline{\text{---}}$
4	Q	Switching signal

PNP

XUM7ABPXM8, XUT7ABPXP02

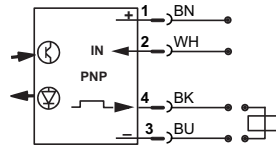

Pre-cabled - 4-wire

+BN (Brown)

IN (input) GY (Grey)

OUT (output) BK (Black)

-BU (Blue)

PNP

XUT7ABPXL2, XUM7ABPXL2

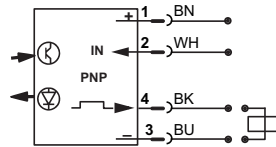

M8 and M12 connector - 4-pin IO-Link



M8

Pin	Signal	Definition
1	+	+ 24 V $\overline{\text{---}}$
2	IN	+ = NO - = NC Open = NO
3	-	0 V $\overline{\text{---}}$
4	C	Communication (IO-Link)



M12

Autodetect PNP/NPN or by IO-Link

XUM8ABAYM8, XUM8ABAYP015, XUT8ABAYP02

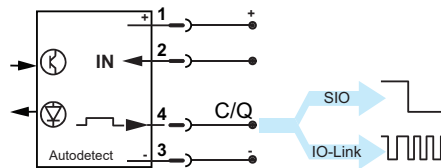

Note: IODD IO-Link files available on our website www.telemecaniquesensors.com/iolink

Wiring schemes

Background suppression sensor

Pre-cabled - 4-wire IO-Link

	Pin	Signal	Definition
+BN (Brown)	1	+	+ 24 V $\overline{\text{---}}$
IN (input) GY (Grey)	2	IN	+ = NO - = NC Open = NO
OUT (output) BK (Black)	3	-	0 V $\overline{\text{---}}$
-BU (Blue)	4	C	Switching signal (SIO) Communication (IO-Link)

Autodetect PNP/NPN or by IO-Link

XUT8ABAYL2

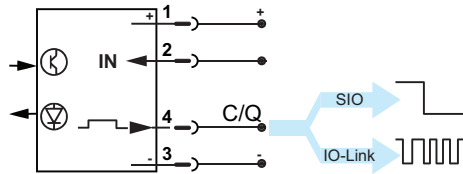

Note: IO-Link files available on our website www.telemecanique.com/iolink

M12 connector - 4-pin

	Pin	Signal	Definition
	1	+	+ 24 V $\overline{\text{---}}$
	2	IN	+ = NC - = NO Open = NO
	3	-	0 V $\overline{\text{---}}$
	4	C	Switching signal

PNP

XUK8ABPXM12

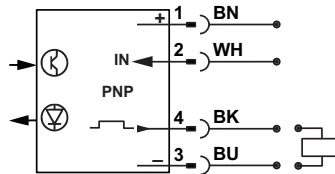

Photo-electric sensors

XU range application

Blue light sensors for very dark object detection

Compact, miniature, and sub-miniature design, plastic

Detection curves

Background suppression sensor

Scanning properties: XUM8ABAY●●

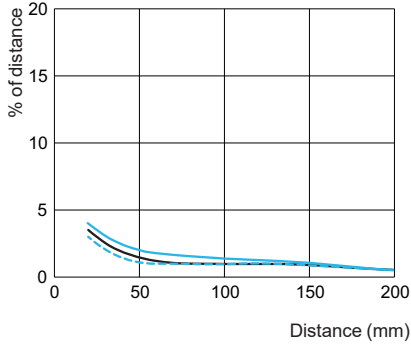

Scanning properties: XUT8ABAY●●

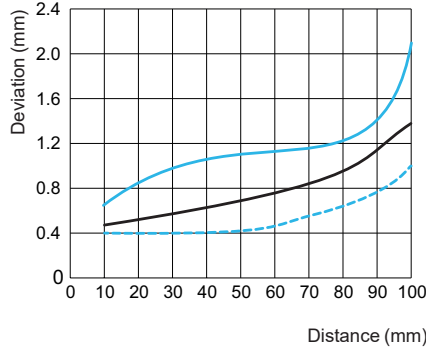

Light spot size: XUT8ABAY●●

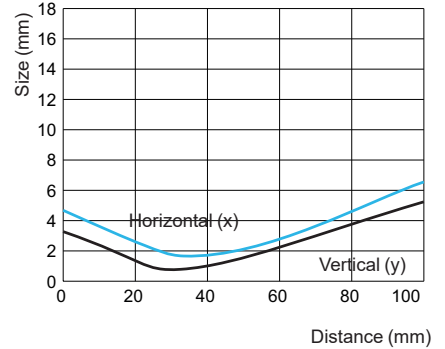

--- Min. distance white object (90%)/white background (90%) (mm)
 — Min. distance grey object (18%)/white background (90%) (mm)
 — Min. distance black object (6%)/white background (90%) (mm)

Light spot size: XUM7ABPX●●

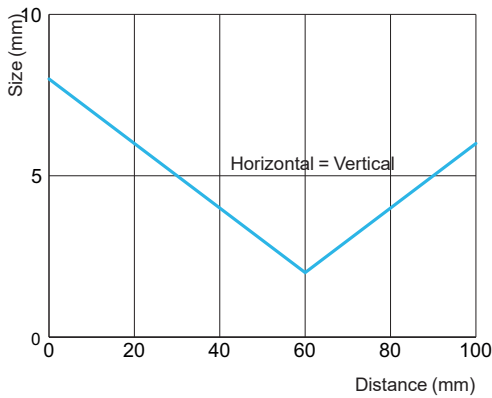

Light spot size: XUT7ABPX●●

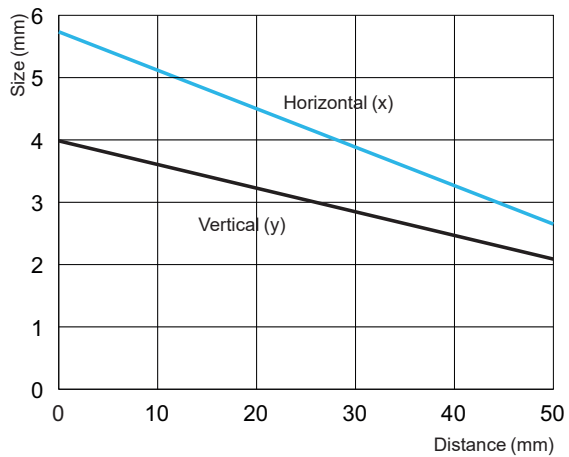

Scanning properties: XUK8ABPXM12

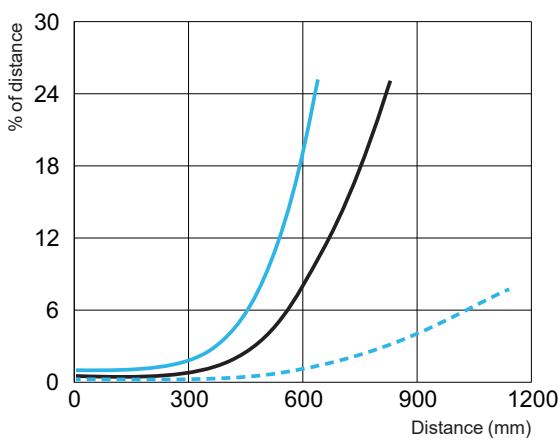

Light beam diameter: XUK8ABPXM12

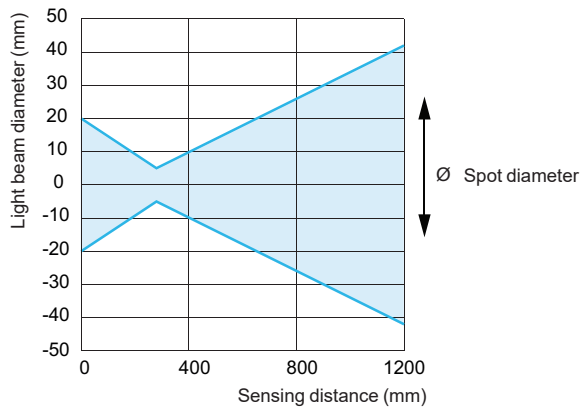

--- Min. distance white object (90%)/white background (90%) (mm)
 — Min. distance grey object (18%)/white background (90%) (mm)
 — Min. distance black object (6%)/white background (90%) (mm)

Photo-electric sensors

XU range application

Blue light sensors for very dark object detection

Compact, miniature, and sub-miniature design, plastic

Dimensions

Compact format: XUK

XUK8ABPXM12

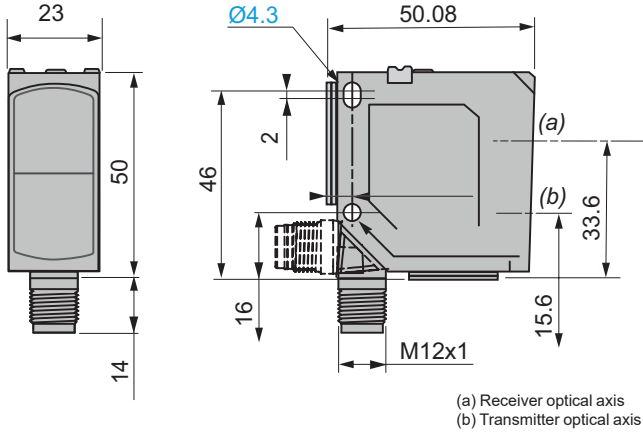

(a) Receiver optical axis
(b) Transmitter optical axis

Miniature format: XUM

XUM7ABPXL2, XUM8ABAYM8

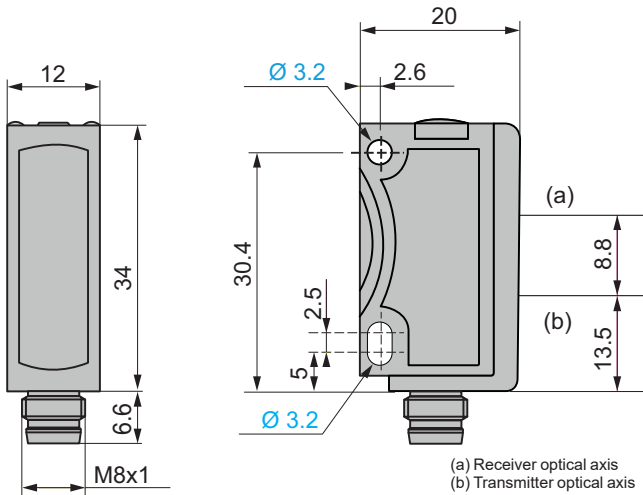

(a) Receiver optical axis
(b) Transmitter optical axis

XUM8ABAYP015

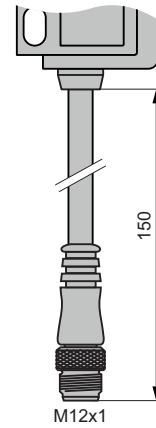

XUM7ABPXL2

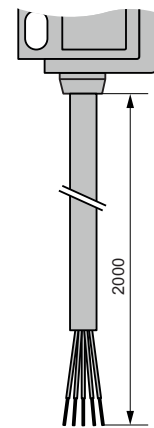

Sub-miniature format: XUT

XUT7ABPXP02, XUT7ABPXL2, XUT8ABAYP02, XUT8ABAYL2

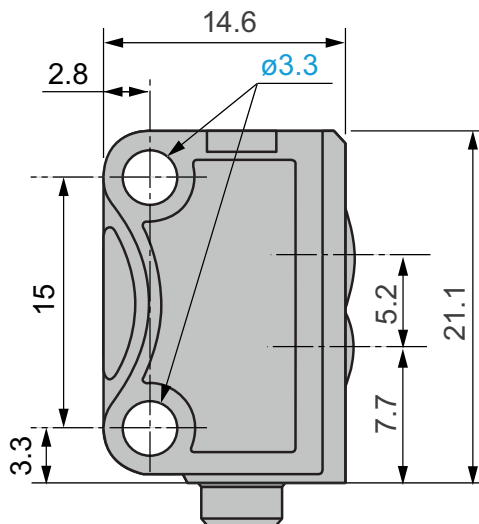

XUT●●●●●P02

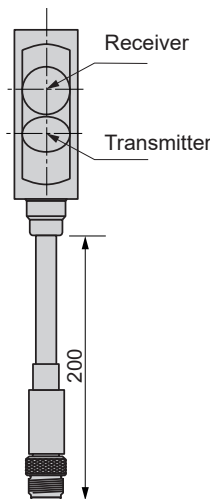

XUT●●●●●L2

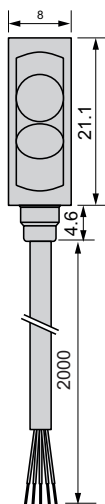

Photo-electric sensors

XU range application

Laser sensors for accurate detection

Miniature and sub-miniature design, plastic



XUM5ALAYM8,
XUM8ALAYM8,
XUM9ALAYM8



XUT8ALAYP02, XUT8ALAYL2,
XUT9ALPXP02, XUT9ALPXL2



XUM8PLPXM8
XUM9PLPXM8



XUM5ALAYP015,
XUM8ALAYP015,
XUM9ALAYP015



XUM5ALAYL2,
XUM8ALAYL2,
XUM9ALAYL2

Laser sensors

Max./operating sensing distance (Sn)	Function	Output	Connection	Reference	Weight (kg)
Diffuse mode detection IO-Link					
250 mm/150 mm	NO/NC configuration via teach-in or IO-Link	Autodetect PNP/NPN	Pre-cabled (L = 2 m)	XUM5ALAYL2	0.045
		Autodetect PNP/NPN	M8 connector (4-pin)	XUM5ALAYM8	0.018
		Autodetect PNP/NPN	Pigtail M12 (L = 0.15 m)	XUM5ALAYP015	0.026

BGS mode detection

BGS mode detection IO-Link					
150 mm/120 mm	NO/NC configuration via teach-in or IO-Link	Autodetect PNP/NPN	Pre-cabled (L = 2 m)	XUM8ALAYL2	0.056
		Autodetect PNP/NPN	M8 connector (4-pin)	XUM8ALAYM8	0.018
		Autodetect PNP/NPN	Pigtail M12 (L = 0.15 m)	XUM8ALAYP015	0.027
100 mm/70 mm	NO/NC configuration via teach-in or IO-Link	Autodetect PNP/NPN	Pre-cabled (L = 2 m)	XUT8ALAYL2	0.031
		Autodetect PNP/NPN	Pigtail M8 (L = 0.2 m)	XUT8ALAYP02	0.019

BGS mode detection

200 mm/130 mm	NO/NC configuration via potentiometer	PNP	M8 connector (4-pin)	XUM8PLPXM8	0.01
---------------	---------------------------------------	-----	----------------------	-------------------	------

Reflex mode detection

Reflex mode detection IO-Link					
15 m/13 m	NO/NC configuration via teach-in or IO-Link	Autodetect PNP/NPN	Pre-cabled (L = 2 m)	XUM9ALAYL2	0.056
		Autodetect PNP/NPN	M8 connector (4-pin)	XUM9ALAYM8	0.018
		Autodetect PNP/NPN	Pigtail M12 (L = 0.15 m)	XUM9ALAYP015	0.027

Reflex mode detection

4 m/3 m	NO/NC configuration via teach-in	PNP	Pre-cabled (L = 2 m)	XUT9ALPXL2	0.031
		PNP	Pigtail M8 (L = 0.2 m)	XUT9ALPXP02	0.019
12 m/10 m	NO/NC configuration via potentiometer	PNP	M8 connector (4-pin)	XUM9PLPXM8	0.01

Accessories

IO-Link Master

See page 78.

Fixing and other accessories

See page 82.

Cabling accessories

See page 88.

Photo-electric sensors

XU range application

Laser sensors for accurate detection

Miniature and sub-miniature design, plastic

Characteristics						
Sensor type			XUM●ALAY●●	XUM●PLPXM8		
Product certifications			CE, UKCA, cULus, Ecolab	CE, UKCA, cULus		
Connection	Connector		M8	M8		
	Pigtail	Length	XUM5, XUM8, XUM9	m	0.15	–
			XUT8, XUT9	m	0.20	–
	Pre-cabled	Length		m	2	–
Maximum sensing distance S_{max}	Diffuse mode		XUM5	mm	1...250	–
	Background suppression system	XUM8		mm	4...150	200
		XUT8		mm	6...70	–
	Reflex mode system		XU●9	m	0.1...13	15
Detection light beam colour			Laser class 1, red			
Degree of protection	Conforming to IEC 60529		IP67 for XUM5, XUT8, XUM8, XUT9, XUM9		IP65/ IP67	
	Conforming to DIN 40050-9		IP69K for XUM5, XUM8, XUM9		–	
Storage temperature			°C	-20...+80	-40...+70	
Operating temperature	XUM5, XUM8, XUM9		°C	-20...+60	-20...+55	
	XUT8, XUT9		°C	-20...+50	–	
Materials	Case	XUM5, XUM8, XUM9		ABS	Glass filled technopolymer	
		XUT8, XUT9		PUR	–	
	Lens		PMMA			
	Front		PMMA		–	
	Cable		PVC		–	
Rated supply voltage			V	12...24 ---	10...30 ---	
Voltage limits (including ripple)			V	10...30 ---		
Current consumption, no-load	XUM5, XUM8, XUM9		mA	≤ 30	≤35	
	XUT8, XUT9		mA	≤ 12	–	
Switching capacity	XUM5, XUM8, XUM9		mA	≤ 100		
	XUT8, XUT9		mA	≤ 50	–	
Maximum switching frequency	XUM5, XUM9		Hz	4000	≤2000	
	XUT8, XUM8, XUT9		Hz	1000	≤2000	
Delays	First-up		ms	< 300	–	
	Response	XUM5		µs	≤ 125	–
		XUM8		µs	≤ 500	250
		XUM9		µs	125	250
		XUT8, XUT9		µs	500	–
	Recovery		ms	< 300	–	
	IO-Link		ms	> 230		

Photo-electric sensors

XU range application

Laser sensors for accurate detection

Miniature and sub-miniature design, plastic

Wiring schemes

Laser sensors

M8 and M12 connector - 4-pin - IO-Link



Pin	Signal	Definition
1	+	+ 24 V $\overline{\text{---}}$
2	IN	+ = NO



3	-	0 V
4	Q	Switching signal (SIO)
	C	Communication (IO-Link)

Autodetect PNP/NPN or by IO-Link

XUM5ALAYM8, XUM5ALAYP015, XUM8ALAYM8, XUM8ALAYP015, XUT8ALAYP02, XUM9ALAYM8, XUM9ALAYP015

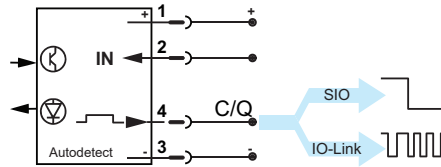

Note: IODD IO-Link files available on the website www.telemecaniquesensors.com/iolink

Pre-cabled - 4-wire - IO-Link



Pin	Signal	Definition
1	+	+ 24 V $\overline{\text{---}}$
2	IN	+ = NO
		- = NC
		Open = NO
3	-	0 V $\overline{\text{---}}$
4	C	Switching signal (SIO)
		Communication (IO-Link)

Autodetect PNP/NPN or by IO-Link

XUM5ALAYL2, XUM8ALAYL2, XUT8ALAYL2, XUM9ALAYL2

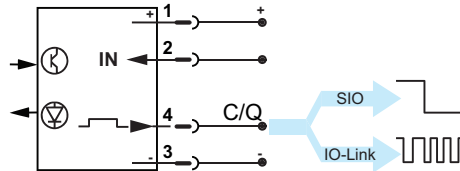

Note: IODD IO-Link files available on the website www.telemecaniquesensors.com/iolink

M8 connector - 4-pin



Pin	Signal	Definition
		XUT9ALPX XUM●PLPX
1	+	+ 24 V $\overline{\text{---}}$ 10...30 V $\overline{\text{---}}$
2	IN	+ = NC Not connected
		- = NO
		Open = NO
3	-	0 V $\overline{\text{---}}$ 0 V $\overline{\text{---}}$
4	Q	Switching PNP output signal

PNP

XUT9ALPXL2, XUT9ALXP02

XUM8PLPXM8, XUM9PLPXM8

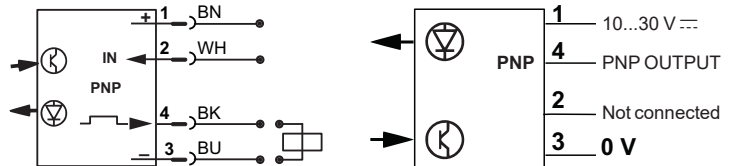

Note: IODD IO-Link files available on the website www.telemecaniquesensors.com/iolink

Photo-electric sensors

XU range application

Laser sensors for accurate detection

Miniature and sub-miniature design, plastic

Dimensions

Miniature format: XUM

XUM●ALAYM8

XUM●ALAYP015

XUM●ALAYL2

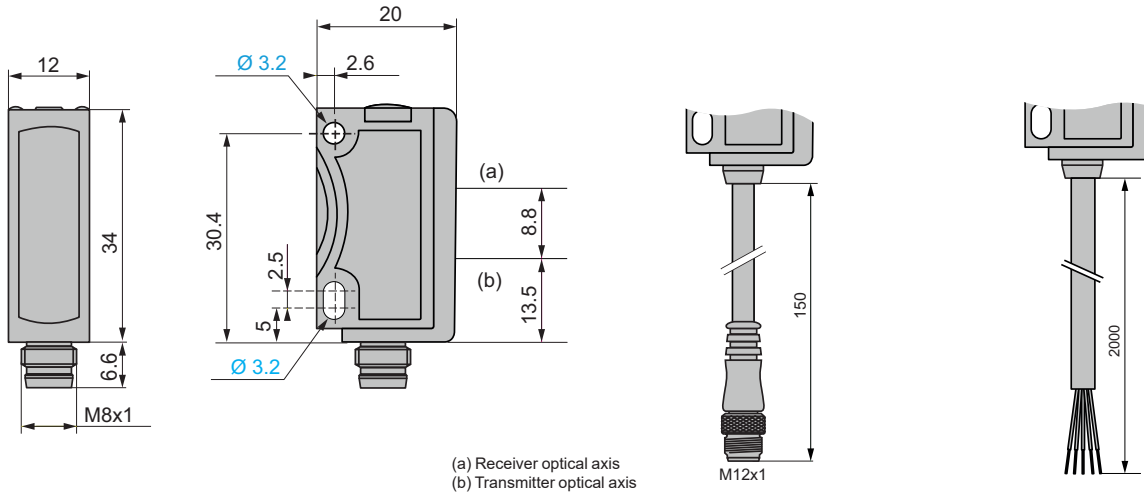

Miniature format: XUM●PLPXM8

XUM8PLPXM8, XUM9PLPXM8

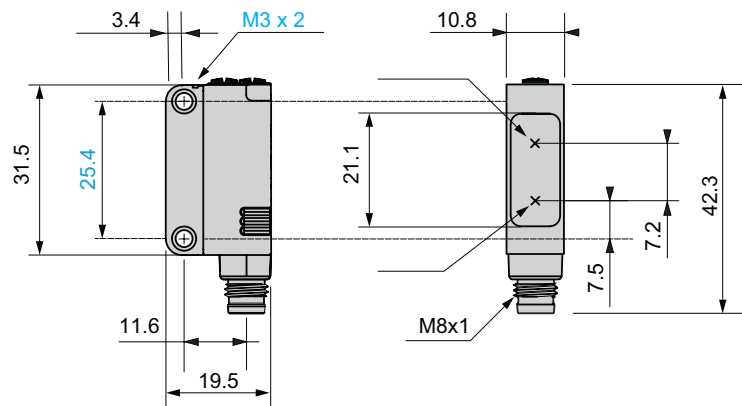

Sub-miniature format: XUT

XUT●●●●●●2

XUT●●●●●P02

XUT●●●●●L2

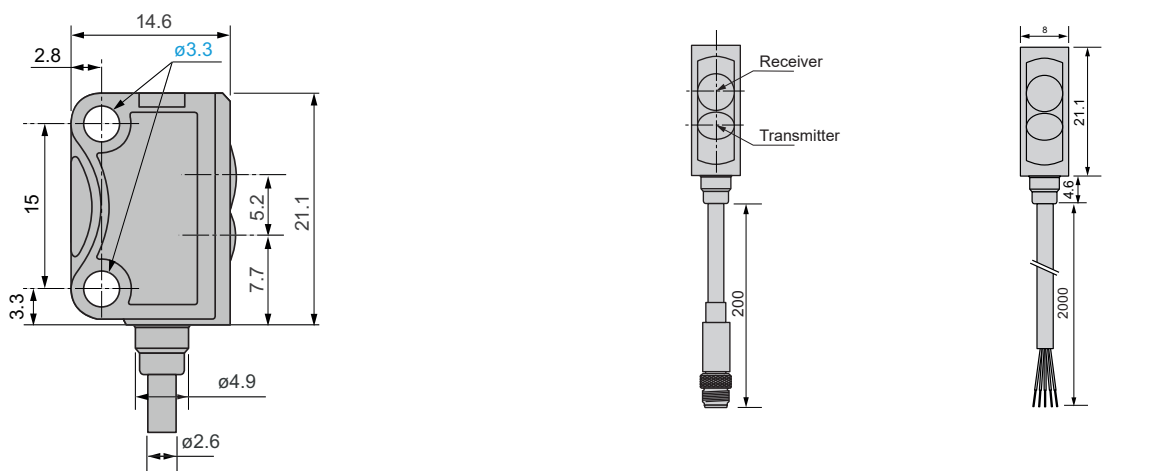

Photo-electric sensors

XU range application

Laser sensors for accurate detection

Miniature and sub-miniature design, plastic

Detection curves

Laser sensor, diffuse mode detection

Light spot size: XUM5ALAY●●

Excess gain: XUM5ALAY●●

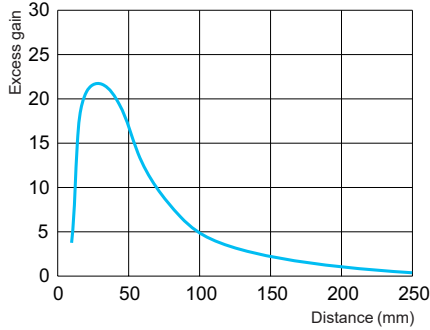
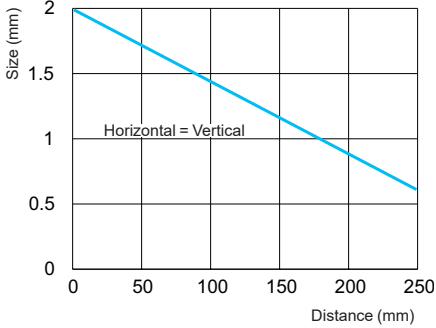

Laser sensor, reflex mode detection: XU●9AL●●

Functional reserves: XUM9ALAY●●

Light spot diameter: XUM9ALAY●●

Light spot size: XUT9ALPX●●

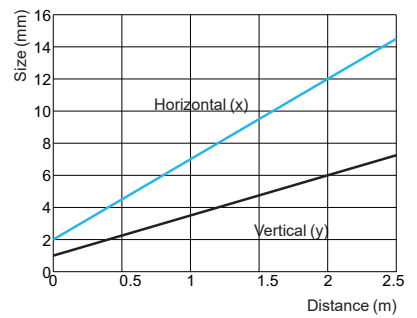
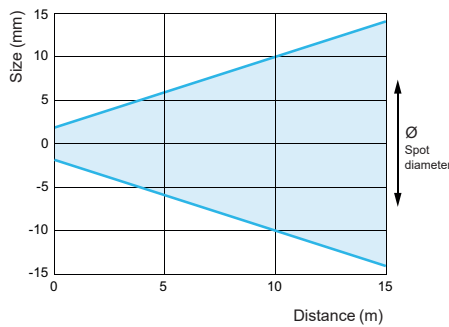
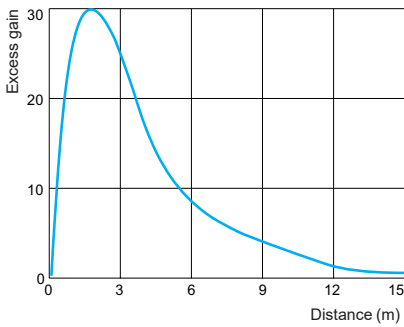

Detection curves

Laser sensor, background suppression mode

Light spot size: XUM8ALAY●●

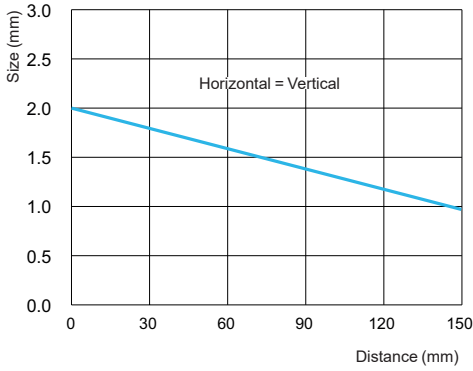

Light spot size: XUT8ALAY●●

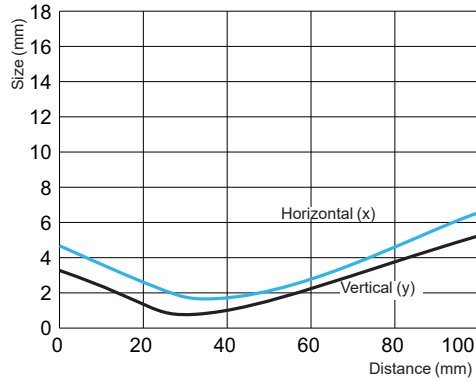

Scanning properties: XUM8ALAY●●

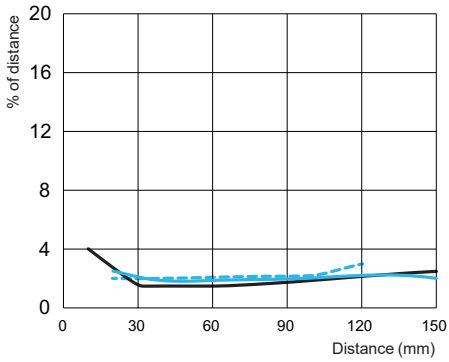

Scanning properties: XUT8ALAY●●

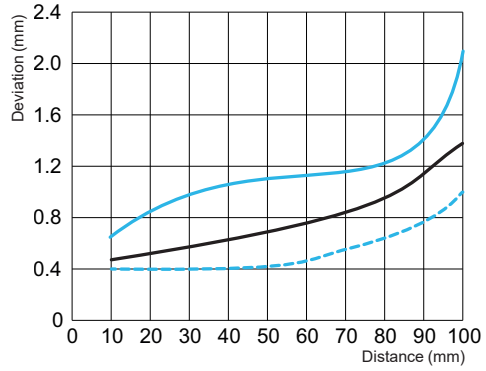

- Min. distance white object (90%)/white background (90%) (mm)
- Min. distance grey object (18%)/white background (90%) (mm)
- Min. distance black object (6%)/white background (90%) (mm)

Photo-electric sensors

XU range application
Sensors for colour object detection
Compact and miniature design, plastic



XUKCBSAYM12



XUKCBLAYM12



XUMRACAYM8

Colour sensors IO-Link

Max./operating sensing distance (Sn)	Function	Output	Connection	Reference	Weight (kg)
--------------------------------------	----------	--------	------------	-----------	-------------

White light, multiple colour

60 mm/30 mm	NO/NC configuration	Autodetect PNP/NPN	M12 connector (3-output)	XUKCBSAYM12	0.017
150 mm/120 mm	via teach-in or IO-Link	Autodetect PNP/NPN	M12 connector (3-output)	XUKCBLAYM12	0.017

RGB light, unique colour

15 mm/12 mm	NO/NC configuration via teach-in or IO-Link	Autodetect PNP/NPN	M8 connector (4-pin)	XUMRACAYM8	0.018
-------------	---	--------------------	----------------------	------------	-------

Accessories

IO-Link Master

See page 78.

Fixing and other accessories

See page 82.

Cabling accessories

See page 88.

Characteristics

Sensor type				XUKCB●AYM12	XUMRACAYM8
Product certifications				CE, UKCA, cULus	CE, UKCA, cULus, Ecolab
Connection		Connector		M12 (5-pin)	M8 (4-pin)
Maximum sensing distance Smax		White light	XUKC short	mm	60
			XUKC long	mm	150
		RGB light	XUMR	mm	–
Detection light beam colour				White	Red, green and blue
Degree of protection		Conforming to IEC 60529		IP67	
		Conforming to DIN 40050-9		IP69K	
Storage temperature				°C	-20...+80
Operating temperature				°C	-20...+55
Materials		Case		Zinc die-cast	ABS
		Lens		PMMA	PMMA
		Front		PMMA	PMMA
		Cable			
Rated supply voltage				V	24 ---
Voltage limits (including ripple)				V	18...30
Current consumption, no-load				mA	≤ 60
Switching capacity				mA	≤ 100
Maximum switching frequency				Hz	3000
Delays		First-up		ms	300
		Response		µs	≤ 180
		Recovery		ms	< 300
		IO-Link		ms	> 230

Wiring schemes

Colour detection system

M12 connector - 5-pin - IO-Link



Pin	Signal	Definition
1	+	+ 24 V $\overline{\text{DC}}$
2	IN	+ = NO - = NC Open = NO
3	-	0 V $\overline{\text{DC}}$
4	Q	Switching signal (SIO)
C		Communication (IO-Link)

Autodetect PNP/NPN or by IO-Link

XUKCB•AYM12, XUMRACAYM8

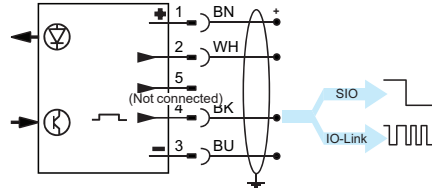

Note: IODD IO-Link files available on our website www.telemecaniquesensors.com/iolink

Detection curves

Colour detection system

Light spot size: XUKCBSAYM12 and XUKCBLAYM12

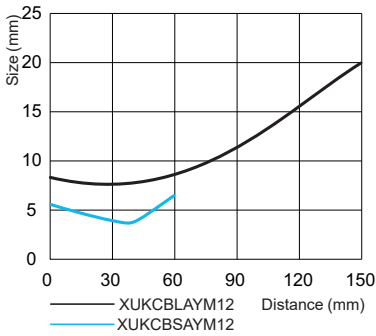

Signal process: XUMRACAYM8

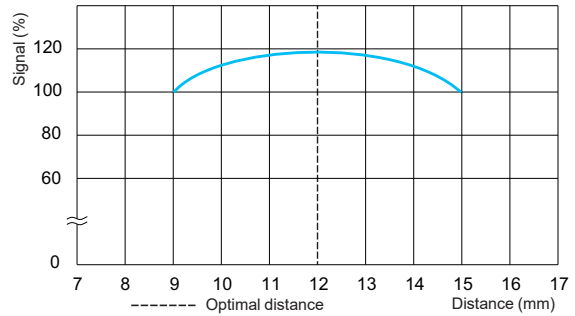

Dimensions

Compact format: XUKCB•AYM12

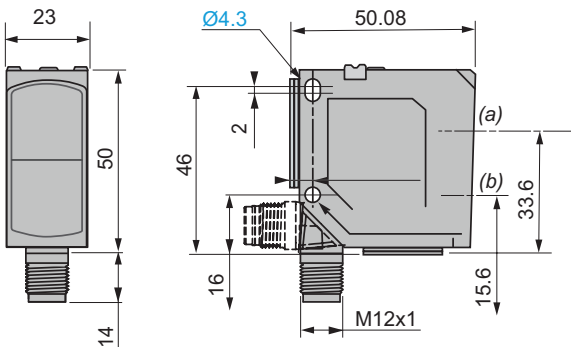

(a) Receiver optical axis
(b) Transmitter optical axis

Miniature format: XUMRACAYM8

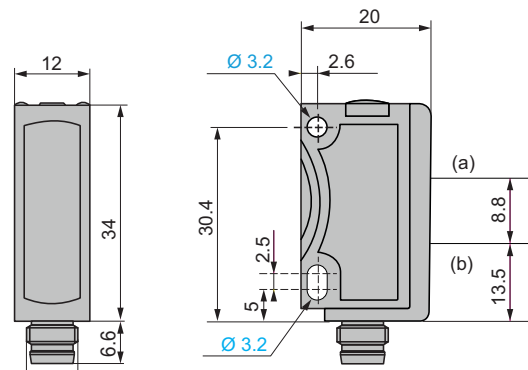

(a) Receiver optical axis
(b) Transmitter optical axis

Photo-electric sensors

XU range application

Sensors for transparent object detection

Miniature, sub-miniature, and compact design, plastic



XUMTARAYM8,
XUM7ABPXM8,
XUM8ABAYM8



XUMTARAYL2,
XUMTARAYP015,
XUM7ABPXL2,
XUM8ABAYP015



XUMTPRPXM8



XUT8ABAYL2,
XUT8ABAYP02,
XUT7ABPXL2,
XUT7ABPXP02



XUK8ABPXM12

Sensors for transparent object detection

Max./operating sensing distance (Sn)	Function	Output	Connection	Reference	Weight (kg)
Polarised reflex system IO-Link					
2 m/2 m	NO/NC configuration via teach-in or IO-Link	Autodetect PNP/NPN	Pre-cabled (L = 2 m)	XUMTARAYL2	0.056
		Autodetect PNP/NPN	M8 connector (4-pin)	XUMTARAYM8	0.018
		Autodetect PNP/NPN	Pigtail M12 (L= 0.15 m)	XUMTARAYP015	0.027

Transparent reflex system

2 m/2 m	NO/NC configuration via potentiometer	PNP	M8 connector (4-pin)	XUMTPRPXM8	0.01
---------	---------------------------------------	-----	----------------------	-------------------	------

BGS mode detection, adjustable

IO-Link

200 mm/200 mm	NO/NC configuration via teach-in or IO-Link	Autodetect PNP/NPN	M8 connector (4-pin)	XUM8ABAYM8	0.014
		Autodetect PNP/NPN	Pigtail M12 (L= 0.15 m)	XUM8ABAYP015	0.027
100 mm/100 mm	NO/NC configuration via teach-in or IO-Link	Autodetect PNP/NPN	Pigtail M8 (L= 0.2 m)	XUT8ABAYP02	0.019
		Autodetect PNP/NPN	Pre-cabled (L = 2 m)	XUT8ABAYL2	0.031

BGS mode detection, not adjustable

100 mm/80 mm	NO/NC configuration via teach-in	PNP	Pre-cabled (L = 2 m)	XUM7ABPXL2	0.056
		PNP	M8 connector (4-pin)	XUM7ABPXM8	0.017
50 mm/50 mm	NO/NC configuration via teach-in	PNP	Pre-cabled (L = 2 m)	XUT7ABPXL2	0.031
		PNP	Pigtail M8 (L= 0.2 m)	XUT7ABPXP02	0.022

BGS mode detection, compact

IO-Link

1200 mm/1200 mm	NO/NC configuration via teach-in or IO-Link	PNP	M12 connector (4-pin)	XUK8ABPXM12	0.046
-----------------	---	-----	-----------------------	--------------------	-------

Accessories

IO-Link Master

See page 78.

Fixing and other accessories

See page 82.

Cabling accessories

See page 88.

Characteristics									
Sensor type				XUMTARAY●●	XU●7ABP●●	XUK8ABP●●	XU●8ABAY●●	XUMTPRPM8	
Product certifications				CE, UKCA, cULus, Ecolab				CE, UKCA, cULus	
Connection	Connector			M8	M8 (for XUM7)	M12	M8	M8	
	Pigtail	Length	XUM8	m	0.15	0.2	-	0.15	
			XUT8					0.2	
	Pre-cabled	Length	m	2	2	-	2	-	
Maximum sensing distance S _{max}	Polarised reflex system XUMTA			m	0...2	-	-	-	
	Transparent reflex system XUMTP			m	-	-	-	2	
	BGS system, not adjustable XUM7			mm	-	0...80	-	-	
	BGS system, adjustable	XUM8			mm	-	-	White = 3...1200 Grey = 5...750 Black = 10...600	-
		XUT8			mm	-	-	3...100	-
BGS system, blue light XUT7			mm	-	2...50	-	-		
Detection light beam colour				Red (LED)	Blue (LED)	Blue (LED)	Blue (LED)	Red (LED)	
Degree of protection	Conforming to IEC 60529			IP67					
	Conforming to DIN 40050-9			IP69K (except XUT)				-	
Storage temperature				°C	-20...+80			-40...+70	
Operating temperature				°C	-20...+60	-20...+50	-20...+60	-25...+55	
Materials	Case	XUM		ABS	ABS	ABS/PC	ABS	Glass-filled technopolymer	
		XUT			PUR		PUR		
	Lens			PMMA					
	Front			PMMA				-	
	Cable			PVC	PVC	-	PVC	-	
Rated supply voltage	XUM		V	24 ---	12...24 ---	12...24 ---	12...24 ---	10...30 ---	
	XUT		V				24 ---		
Voltage limits (including ripple)				V	10...30				
Current consumption, no-load	XUM		mA	≤ 30	≤ 30	≤ 30	≤ 30	≤35m	
	XUT		mA		≤ 20		≤ 20		
Switching capacity	XUM		mA	≤ 100	≤ 100	≤ 100	≤ 100	≤ 100	
	XUT		mA		≤ 50		≤ 50		
Maximum switching frequency				Hz	1000	1000	600	700	1000
Delays	First-up			ms	< 300				-
	Response	XUM		µs	500		830	500	500
		XUT		µs				700	
	Recovery			ms	< 300				-
IO-Link					> 230	-	> 230	> 230	-

Wiring schemes

Polarised reflex system

M8 and M12 connector - 4-pin - or pre-cabled - 4-wire IO-Link

Pin	Signal	Definition
1	+	+ 24 V $\overline{\text{---}}$
2	IN	+ = NO - = NC Open = NO
3	-	0 V $\overline{\text{---}}$
4	Q	Switching signal (SIO)
	C	Communication (IO-Link)

PNP XUMTARAYL2, XUMTARAYM8, XUMTARAYP015

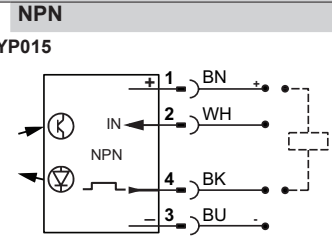
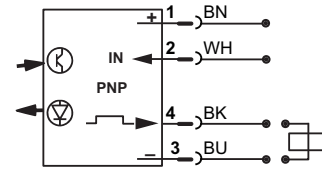

Note: IODD IO-Link files available on the website www.telemecaniquesensors.com/iolink

BGS mode detection, adjustable IO-Link

M8 and M12 connector - 4-pin - or pre-cabled - 4-wire

Pin	Signal	Definition
1	+	+ 24 V $\overline{\text{---}}$
2	IN	+ = NO - = NC Open = NO
3	-	0 V $\overline{\text{---}}$
4	Q	Switching signal (SIO)
	C	Communication (IO-Link)

PNP XUM8ABAYM8, XUM8ABAYP015, XUT8ABAYP02, XUT8ABAYL2

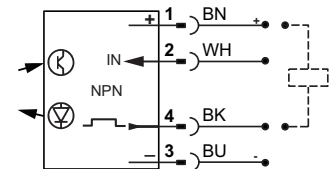
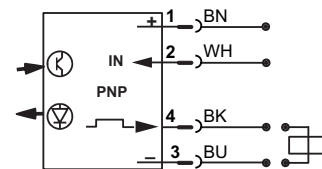

Note: IODD IO-Link files available on the website www.telemecaniquesensors.com/iolink

BGS mode detection, not adjustable

M8 connector - 4-pin - or pre-cabled - 4-wire

Pin	Signal	Definition
1	+	+ 24 V $\overline{\text{---}}$
2	IN	+ = NC - = NO Open = NO
3	-	0 V $\overline{\text{---}}$
4	Q	Switching signal

PNP M8 connector XUM7ABPXM8, XUT7ABXP02

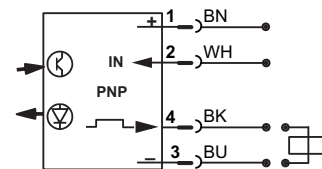

Pre-cabled XUM7ABPXL2, XUT7ABPXL2

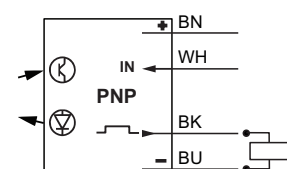

Note: IODD IO-Link files available on the website www.telemecaniquesensors.com/iolink

M12 connector - 4-pin

Pin	Signal	Definition
1	+	+ 24 V $\overline{\text{---}}$
2	IN	+ = NC - = NO Open = NO
3	-	0 V $\overline{\text{---}}$
4	Q	Switching signal

PNP XUK8ABPXM12

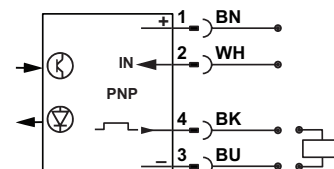

Note: IODD IO-Link files available on the website www.telemecaniquesensors.com/iolink

Transparent reflex

M8 connector - 4-pin

Pin	Definition
1	10...30 Vdc
2	Not connected
3	0 V
4	PNP OUTPUT

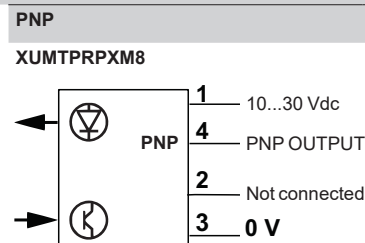

Photo-electric sensors

XU range application

Sensors for transparent object detection

Miniature, sub-miniature, and compact design, plastic

Dimensions

Miniature format: XUM

XUM●A●AYM8, XUM●A●AYL2, XUM●A●AYP015, XUM●ABPX●●

XUM●●●●●●P015

XUM●●●●●●L2

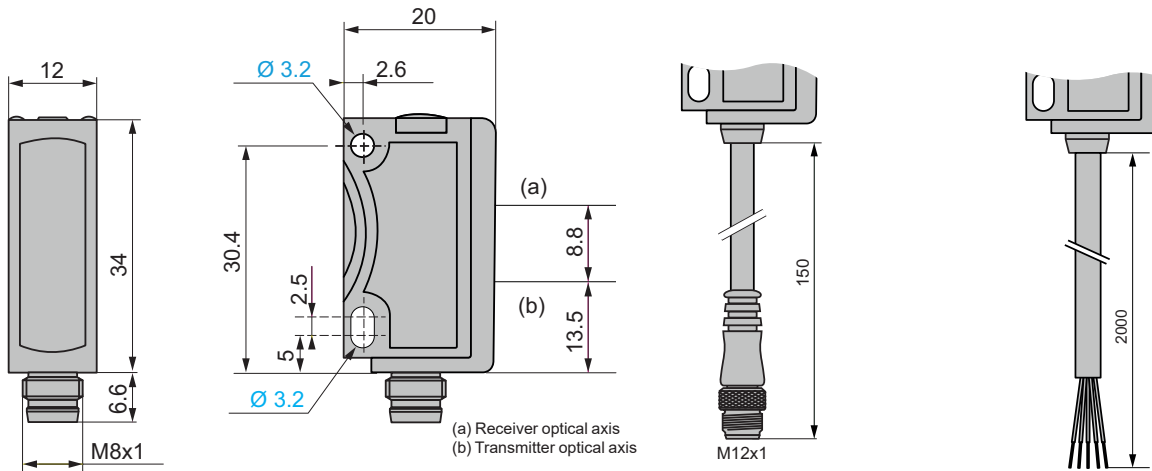

Miniature format: XUM

XUMTPRPM8

Sub-miniature format: XUT

XUT7ABXP02, XUT7ABPXL2, XUT8ABAYL2, XUT8ABAYP02

XUT●●●●●●P02

XUT●●●●●●L2

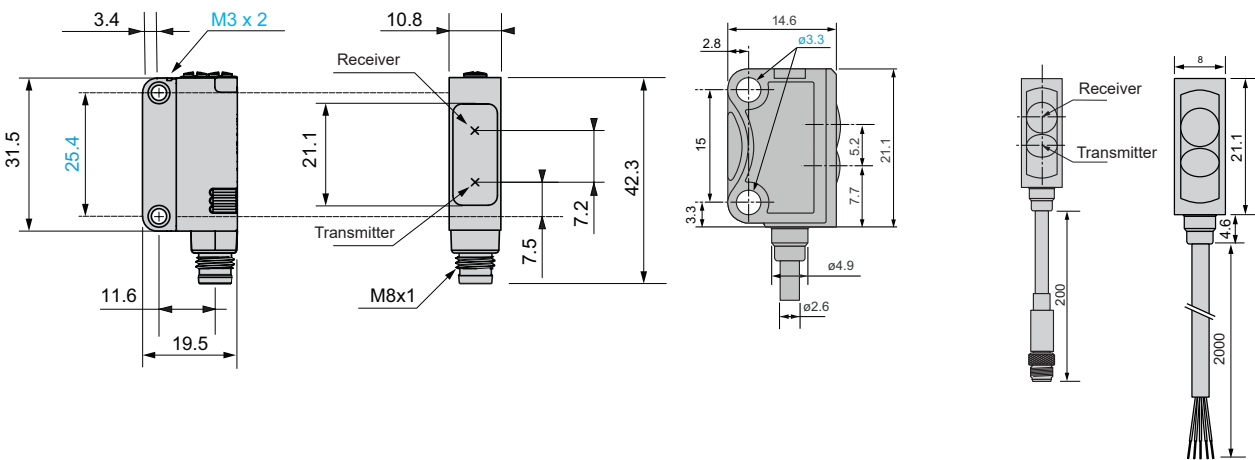

Compact format: XUK

XUK8ABPXM12

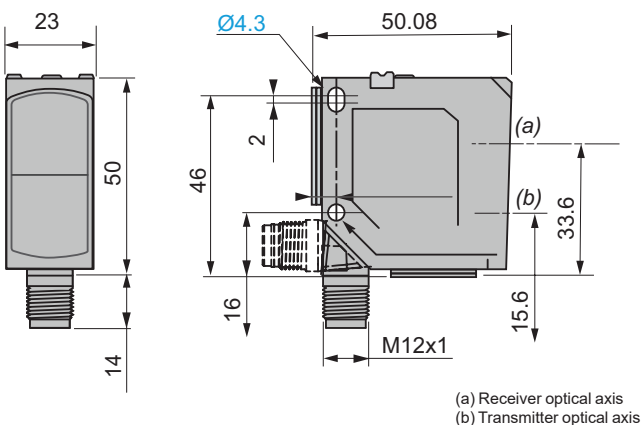

Detection curves

Polarised reflex

Light spot diameter: XUMTARAY●●

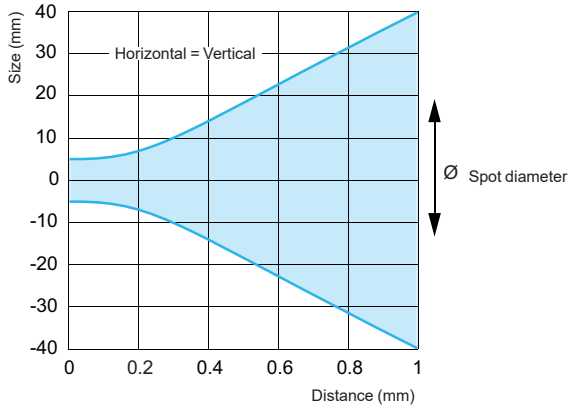

Background suppression mode

Light spot diameter: XUK8ABPXM12

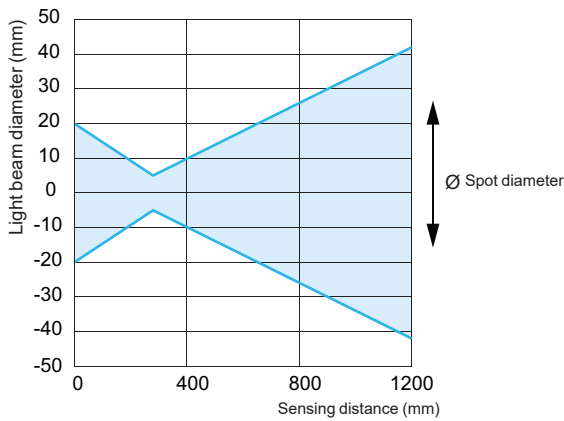

Detection curves

Background suppression mode

Scanning properties: XUT8ABAY●●

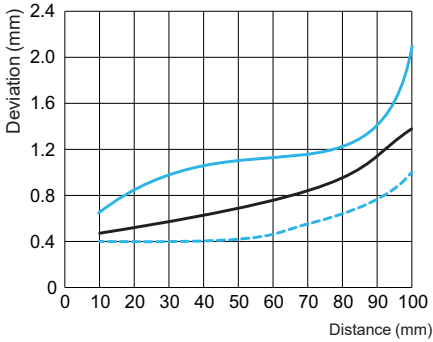

Scanning properties: XUK8ABPXM12

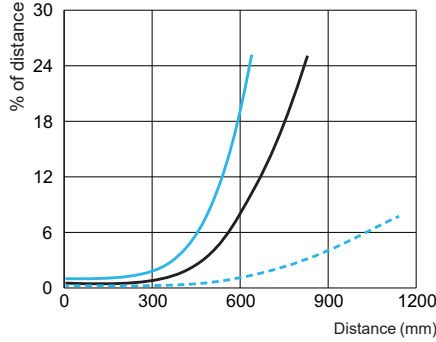

Scanning properties: XUM8ABAY●●

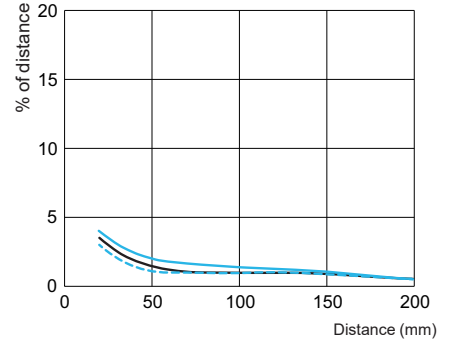

--- Min. distance white object (90%)/white background (90%) (mm)
 — Min. distance grey object (18%)/white background (90%) (mm)
 — Min. distance black object (6%)/white background (90%) (mm)

Light spot size: XUM7ABPX●●

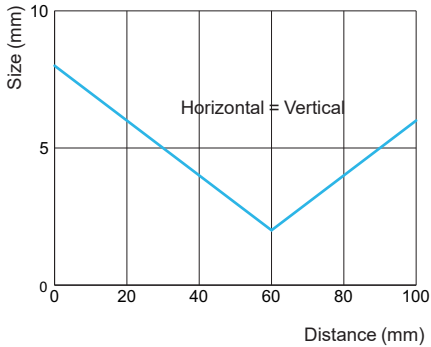

Light spot size: XUT7ABPX●●

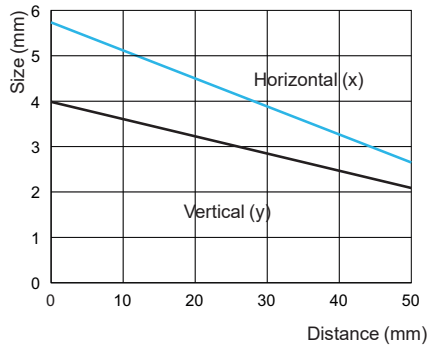

Light spot size: XUT8ABAY●●

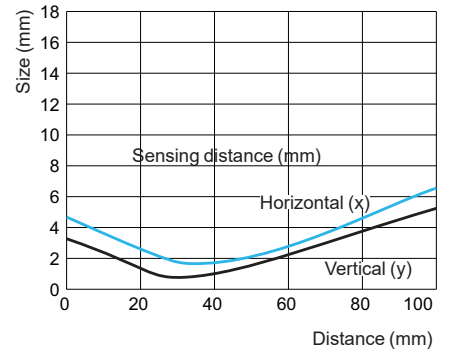

IO-Link



XZ10M8AM12PY

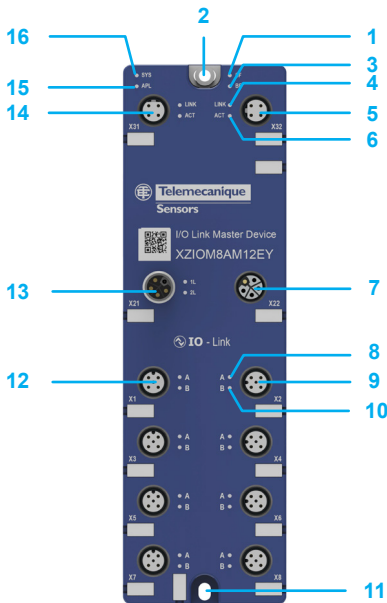

- 1 For Ethernet, module status LED (MS)
For PROFINET, system error LED (SF)
- 2 Fixing hole and functional earth (FE)
- 3 For Ethernet, network status LED (NS)
For PROFINET, bus failure LED (BF)
- 4 Link LED X32
- 5 Ethernet interface, M12, D-coded, port 2
- 6 Activity LED X32
- 7 Power Out
- 8 IO-Link status LED, port 2, channel A
- 9 IO-Link, port 2, M12, A-coded
- 10 IO-Link status LED, port 2, channel B
- 11 Fixing hole
- 12 IO-Link, port 1, M12, A-coded
- 13 Power In
- 14 Ethernet interface, M12, D-coded, port 1
- 15 Application status LED
- 16 System status LED

Presentation

IO-Link is a point-to-point network communication protocol dedicated to sensors and actuators offering advantages such as increased productivity, simplified integration and reduced inventory.

It enables:

- Simplified connection of sensors and actuators to the upper-level control and monitoring system of an automated line
- Advanced diagnostic functions, through continuous monitoring of critical parameters such as signal quality and sensor status
- Reduced commissioning time due to fewer cables and hot swappable devices
- Integration with third-party devices, thanks to multiple fieldbus protocol support (PROFINET, Ethernet/IP)

Telemecanique Sensors offers a wide choice of IO-Link conformant devices, with various detection systems such as thru-beam, diffuse, polarised reflex, etc.

IO-Link system

An IO-Link system consists of the following components:

- IO-Link Master
- IO-Link devices (sensors, RFID readers, valves, motor starters, I/O modules)
- Cabling
- Engineering tool for integration and configuration of IO-Link devices (Simply Config IO-Link Master software (1))

Description

IO-Link Masters

IO-Link Masters serve to capture digital inputs and outputs being conveyed between the PLC and the IO-Link devices.

Two types of IO-Link Master are available:

- **XZ10M8AM12EY** Ethernet Master, for devices connected to an Ethernet/IP network
- **XZ10M8AM12PY** PROFINET Master, for devices connected to a PROFINET network

An IO-Link Master enables:

- On the sensor side: IODD file management, sensor configuration, port diagnosis
- On the Master side: Master configuration, firmware update, factory reset, Master diagnosis, MQTT setting

Example of installation in line or star topology

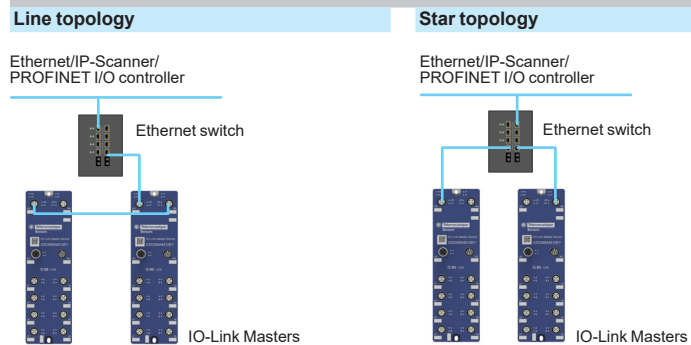

(1) Simply Config IO-Link software can be downloaded from [our website](#).

IO-Link Master devices

Description	Protocol	Power consumption	Number of ports	Connector	Reference	Weight (kg)
IO-Link Master	Ethernet/IP	24V $\overline{\text{---}}$	8 class A	M12	XZIOM8AM12EY	0.405
	PROFINET	24V $\overline{\text{---}}$	8 class A	M12	XZIOM8AM12PY	0.405

IO-Link cables

Power cables

Description	Type of connector	End fittings	Length m		Reference	Weight (kg)	
Single-ended, pre-wired, L-coded power cable (PUR)	Female	5-pin (4+FE)	2	1.5 mm ²	XZCPK75DL2	0.255	
			5	1.5 mm ²	XZCPK75DL5	0.585	
			2	1.5 mm ²	XZCPK75CL2	0.255	
			5	1.5 mm ²	XZCPK75CL5	0.585	
			Jumper power cable (PUR)		Male/ Female	M12 5-pin/M12 5-pin	2
				5	1.5 mm ²	XZCR25K25DL5	0.615
				2	1.5 mm ²	XZCR26K26CL2	0.285
				5	1.5 mm ²	XZCR26K26CL5	0.615

Communication cables

Description	Type of connector	Length (m)	Reference
Ethernet copper cable	M12 D-coded to RJ45, straight/straight	3	XGSZ12E4503
		10	XGSZ12E4510
Ethernet copper cable, shielded	Jumper M12/RJ45, straight/elbowed	3	XGSZ22E4503
		10	XGSZ22E4510

IO-Link connector

Description	Type of connector	End fittings	Reference	Weight (kg)
A-coded M12 T-connector	1 Male/2 Female	M12 5-pin/M12 5-pin	TCSCTN011M11F	0.035kg

Dimensions

XZIOM8AM12●Y

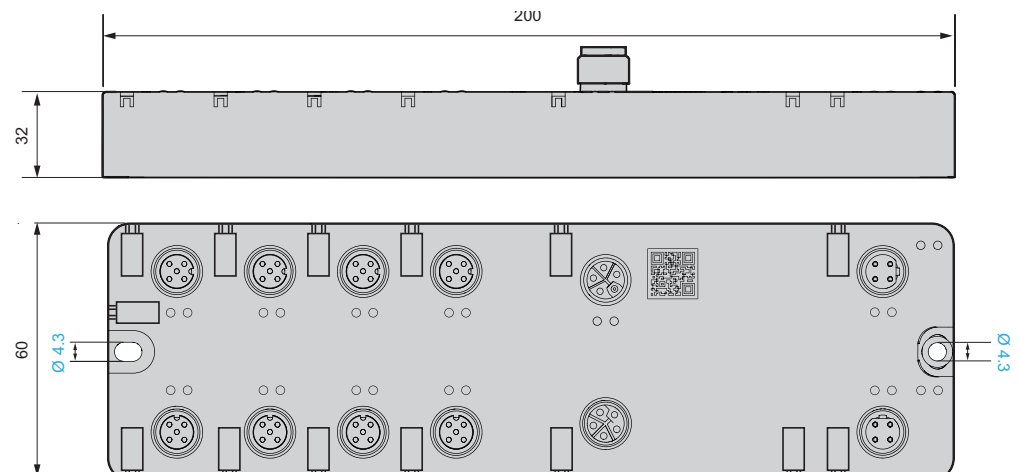

Product specifications				
Reference			XZIOM8AM12EY	XZIOM8AM12PY
Function			Ethernet/IP IO-Link Master	ProfiNet IO-Link Master
Power supply 1L, 2L	Supply voltage 1L, 2L	V	24, -25%/+30% (18...31.2)	
	Low voltage warning 1L	V	18.0 (± 5% at 25 °C) notification on, 18.3 (± 5% at 25 °C) notification off	
	Overvoltage warning 1L	V	30.0 (± 5% at 25 °C) notification on, 29.7 (± 5% at 25 °C) notification off	
	Current consumption	A	1L: 0.1...16 (at 24 V DC) 2L: 0.01...16 (at 24 V DC)	
	Current consumption of supply port	A	Max. 16	
	Conductor cross-section	mm²	0.5...2.5	
	Connector		PWR IN: M12 L-coded, 5-pin, male PWR OUT: M12 L-coded, 5-pin, female	
	Torque	Nm	1.0	
	Reverse polarity protection		Yes	
	Power supply	V	24 --- PELV (Protective Extra Low Voltage) or SELV (Safety Extra Low Voltage)	
Total load	Maximum total load current	A	15.7	
Device	Dimensions (L x W x H)	mm	200 x 60 x 32	
	Weight	g	404	
	Housing		Plastic	
	Potting		Solvent-free electro-casting resin system based on 2 K polyurethane	
	Degree of protection		IP67 (EN 60529)	
	Protection class		III (EN 61140)	
	Mounting		Screw mounting on carrier, 2x M4	
Environmental conditions	Location of operation		Indoor	
	Ambient temperature (operation)	°C	-25...+70	
	Ambient temperature (storage)	°C	-40...+80	
	Maximum temperature change	K/min	3	
	Relative humidity		5%...95%	
	Degree of pollution		3 (EN 60664-1)	
	Altitude	m	0...2000	
	Overvoltage category		II (EN 60664-1)	
	Degree of protection		IP67 (EN 60529)	
	Protection class		III (EN 61140)	
Electrical characteristics	Insulation resistance	V	60 ---	
	Test voltage	V	550 ~ RMS	
	Minimal creepage distance	mm	0.7	
Ethernet connector	Communication interface		Ethernet	
	Autonegotiation, autocrossover		Yes	
	Connector		2x M12, D-coded, female, 4-pin	
	Torque	Nm	1.0	
IO-Link connector	Connector		8x M12, A-coded, male, 5-pin	
	Torque	Nm	1.0	
	Operating modes		Pin 2: DI or DO Pin 4: IO-Link Master, DI or DO	
LEDs	SYS		System status, green/yellow	
	APL		Application status, red/green	
	MS		Module status (EtherNet/IP), red/green	-
	SF		-	System error (PROFINET), red
	NS		Network status (EtherNet/IP), red/green	-
	BF		-	Bus error (PROFINET), red
	LINK		Link status, green	
	ACT		Activity status, yellow	
	1L, 2L		Supply voltage status, red/green	
	A, B		Port status: red/green/yellow (yellow by simultaneous red and green)	
Compliance	RoHS		Yes	
Compliance with EMC guidelines	CE sign		Yes	
	UKCA sign		Yes	
	Emission		EN 61000-6-4/BS EN 61000-6-4	
	Immunity		EN 61000-6-2/BS EN 61000-6-2	

Wiring schemes

Power supply

M12 connector - 5 pins (4 + FE) - IO-Link

Supply voltage input

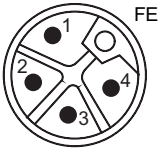

Supply voltage input

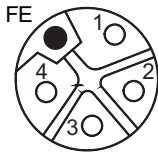

Pin	Signal	Wire colour	Description
1	1L+	Brown	24 V $\overline{\text{DC}}$
2	2L-	White	Reference potential for 2L
3	1L-	Blue	Reference potential for 1L
4	2L+	Black	24 V $\overline{\text{DC}}$ auxiliary/control voltage U2L
FE	FE	Pink	Functional earth

Communication

M12 connector - D-coded - socket - 4 pins

Ethernet

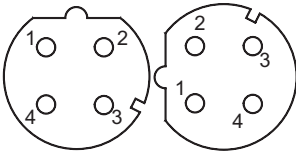

Pin	Signal	Wire colour	Description
1	TX+	Brown	Transmit data positive
2	RX+	White	Receive data positive
3	TX-	Blue	Transmit data negative
4	RX-	Black	Receive data negative

IO-Link ports (Class A)

M12 connector - 4 pins

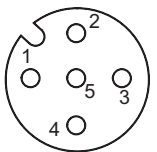

Pin	Signal	Wire colour	Description
1	+	Brown	+24 V DC supply voltage U 1L for sensor/actuator
2	IN	White	Digital input/output channel B
3	-	Blue	Functional earth for 1L+
4	Q	Black	IO-Link data or Digital input/output channel A
5	-	-	Not connected

Auto-detect PNP/NPN or by IO-Link IO-Link

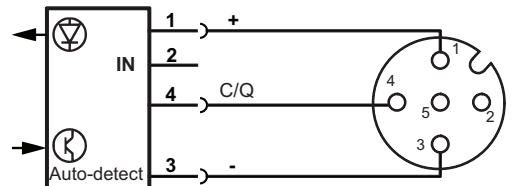

Derating curves

XZIOM8AM12EY and XZIOM8AM12PY

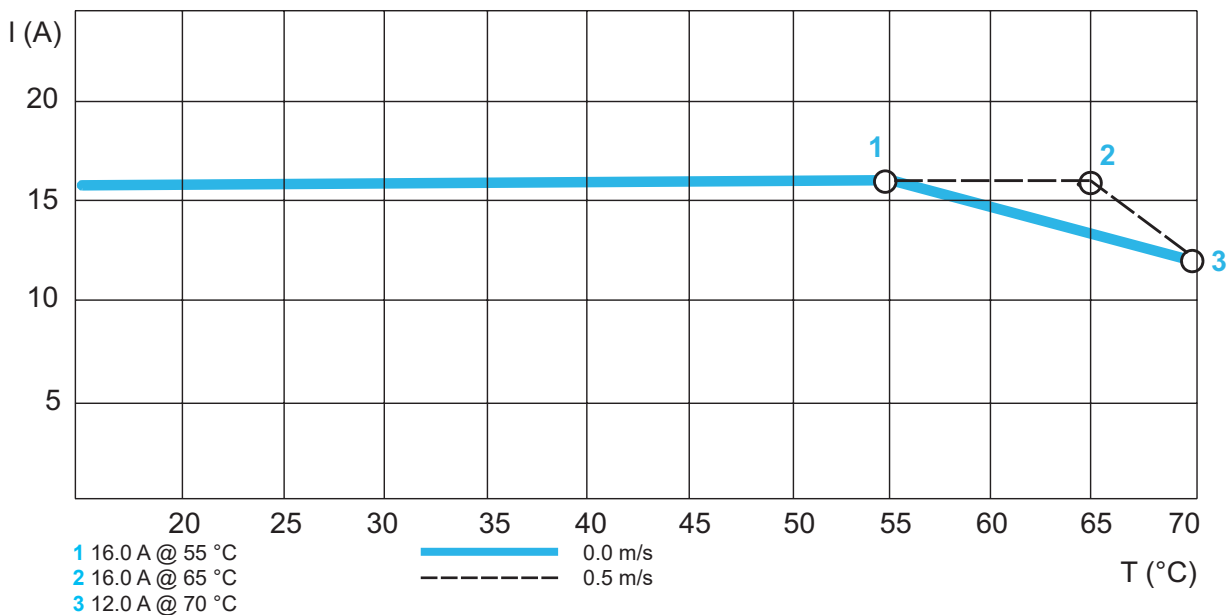

Photo-electric sensors

XU general purpose and Application Accessories

Fixing brackets



XUZASM02 XUZASM03 XUZASM04

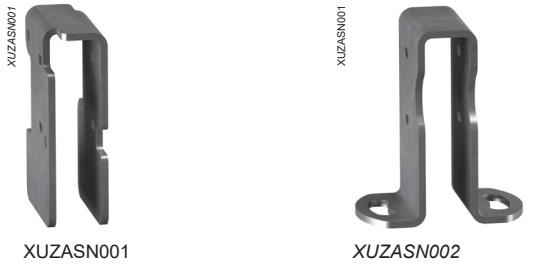

XUZASN001 XUZASN002

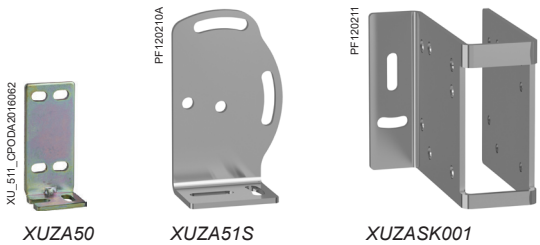

XUZA50 XUZA51S XUZASK001



XUZASW001 XUZASW002 XUZA118 XUZA218

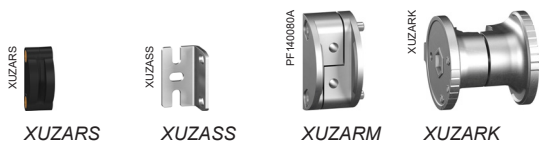

XUZARS XUZASS XUZARM XUZARK

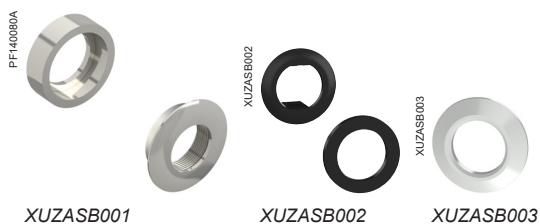

XUZASB001 XUZASB002 XUZASB003

Fixing accessories

Fixing brackets

Description	For use with sensors	Reference	Weight kg
Wrap-around horizontal mounting bracket for pre-cabled sensors Supplied with 2 x M3 screws	XUM●A●XBL2	XUZASM02	0.030
Wrap-around vertical mounting bracket for pre-cabled sensors Supplied with 2 x M3 screws	XUM●A●XBL2	XUZASM03	0.062
Rear mounting bracket Supplied with 2 x M3 screws	XUM●A●XBL2, XUM●A●XBM8	XUZASM04	0.030
Stainless steel grade 316 fixing bracket Supplied with 2 x M3 screws	XUN	XUZASN001	0.124
Wrap-around vertical mounting bracket for pre-cabled sensors Supplied with 2 x M3 screws	XUN	XUZASN002	0.133
Metal fixing bracket Supplied with 2 x M3 screws	XUM, XUT, XUK	XUZA50	0.025
Stainless steel grade 316 fixing brackets Supplied with 2 x M3 screws	XUK8ABPXM12	XUZA51S	0.050
Stainless steel grade 304 fixing bracket for compact sensor 50 x 50 mm Supplied with 2 x M3 screws	XUK8ABPXM12	XUZASK001	0.240
Metal dovetail fixing clamp, 1 axis Supplied with 1 x M3 screw	XUK8ABPXM12	XUZASW001	0.014
Simple metal fixing bracket Supplied with 2 x M3 screws	XUK8ABPXM12	XUZASW002	0.017
90° stainless steel fixing brackets	XUB	XUZA118	0.045
Plastic fixing bracket with adjustable ball joint	XUB	XUZA218	0.035
Dovetail clamp Supplied with 2 x M3 screws	XUT7ABPX●●, XUT8A●AY●●, XUT9ABPX●●	XUZARS	0.005
Mounting bracket Supplied with 2 x M3 screws	XUT7ABPX●●, XUT8A●AY●●, XUT9ABPX●●	XUZASS	0.008
Dovetail clamp Supplied with 2 x M3 screws	XUM●A●AYM8, XUM●A●AYP015, XUM●A●AYL2, XUM7ABPX●●	XUZARM	0.017
Dovetail clamp Supplied with 1 x M3 screw	XUKCB●AYM12, XUK8ABPXM12	XUZARK	0.026

Mounting rings

Description	For use with sensors	Reference	Weight kg
Stainless steel flush mounting nut	XUB	XUZASB001	0.018
Plastic mounting ring 27 mm x 16.8 mm	XUB	XUZASB002	0.003
Metal mounting ring 30 mm x 18 mm	XUB	XUZASB003	0.011

Cabling accessories

See pages 88 to 93.

Fixing accessories

Fixing brackets

XUZASM04

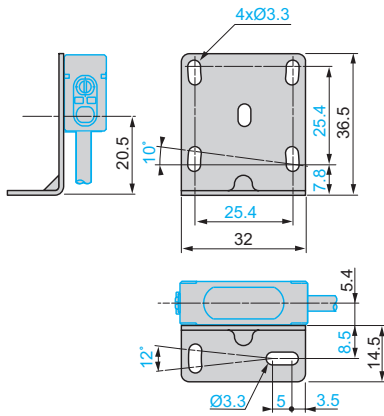

XUZASM03

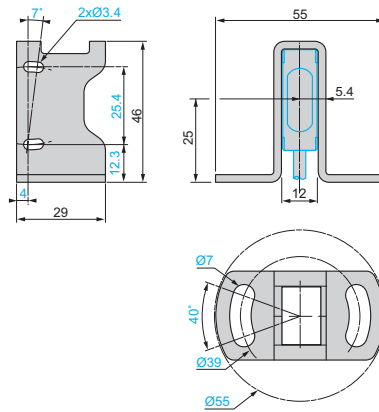

XUZASM02

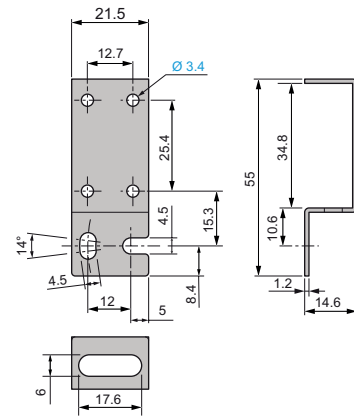

XUZASN001

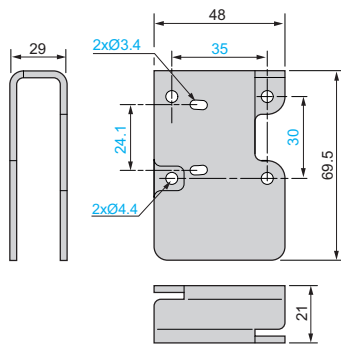

XUZASN002

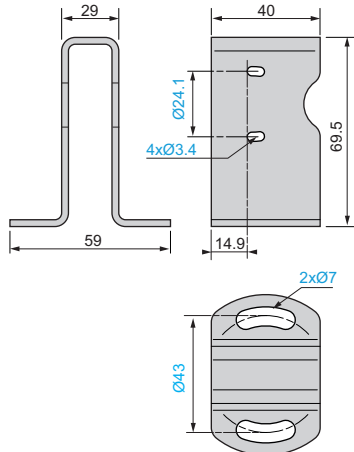

XUZA50

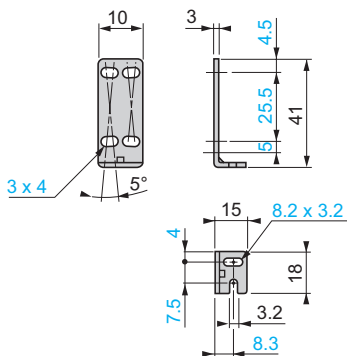

Fixing accessories

Fixing brackets

XUZA51S

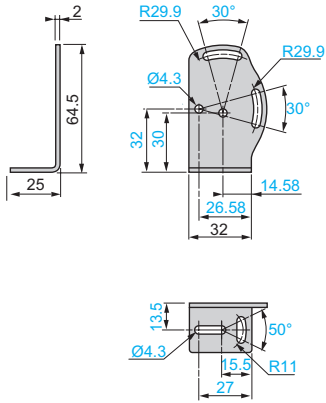

XUZASK001

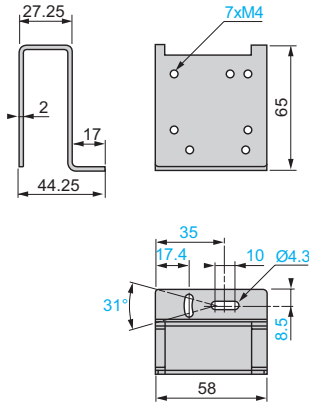

XUZASW001

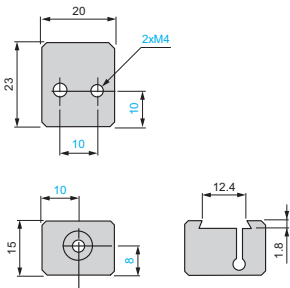

XUZASW002

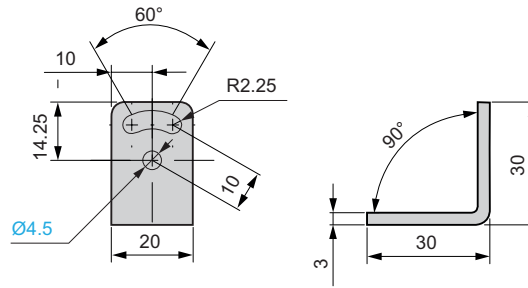

XUZA118

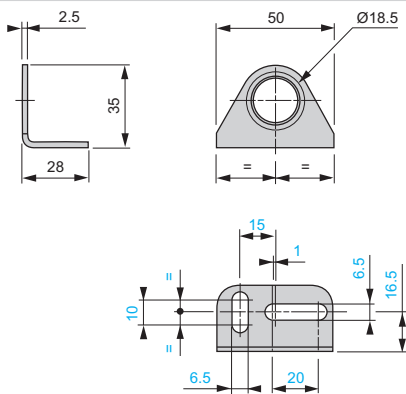

XUZA218

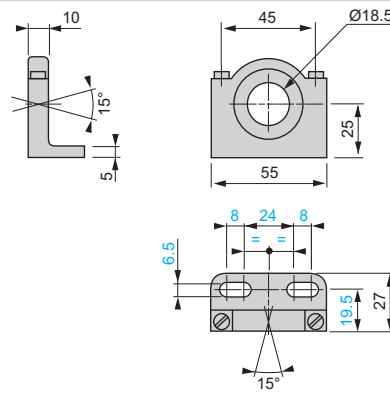

Fixing accessories

Fixing brackets

XUZARS

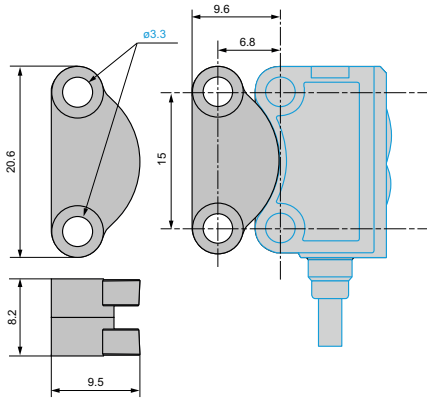

XUZASS

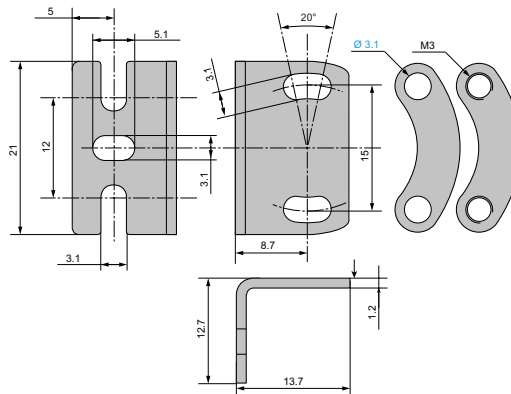

XUZARM

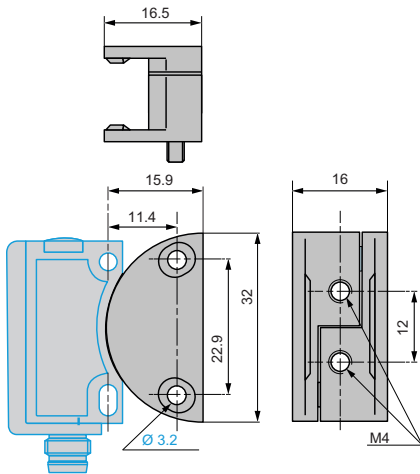

XUZARK

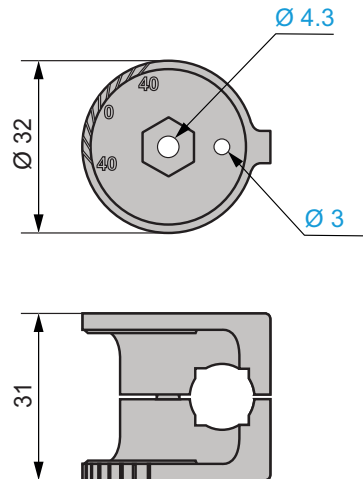

Mounting rings

XUZASB001

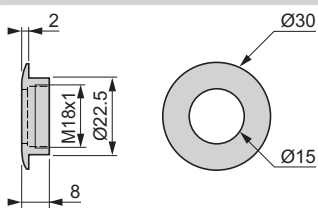

XUZASB002

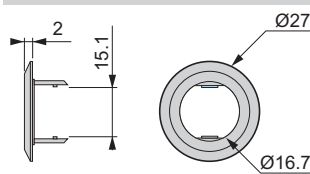

XUZASB003

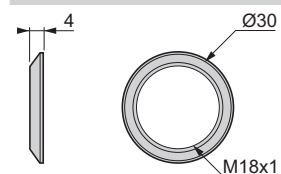

Photo-electric sensors

XU general purpose and XU Application Accessories

Reflectors



XUZC50_30

XUZC50●●



XU_511_L_PFR180019

XUZC60S11

XU_511_C_PODAA016073



XUZCR0401HP



XU_511_L_PFR180005

XUZC39

Reflectors

Description	Size	Fixing mode	Chemical resistance	Reference	Weight kg
Universal (generic) devices					
Rigid square reflectors	100 mm x 100 mm	2 brackets (not provided)	No	XUZC100	0.035
	51.5 mm x 69 mm	6 holes	No	XUZC50	0.020
Rigid rectangle reflectors	45 mm x 29 mm	2 holes	No	XUZC24	0.010
	40 mm x 60 mm	2 holes	No	XUZC60S11	0.022
Rigid circular reflectors	Ø 39 mm	Adhesive	No	XUZC39	0.008
For laser products					
Rigid square reflectors	50 mm x 50 mm	6 holes	No	XUZC50HP	0.020
Rigid rectangle reflectors	40 mm x 18 mm	2 holes	No	XUZCR0401HP	0.010
	60 mm x 19 mm	2 holes	Ecolab	XUZCR0401CRHP	0.010
For food & beverage					
Rigid square reflectors	50 mm x 50 mm	6 holes	Ecolab	XUZC50CR	0.200

Cabling accessories

See pages 88 to 93.

Reflectors

Dimensions

XUZC100

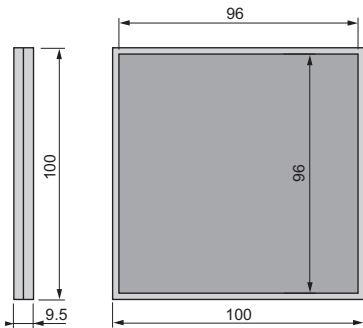

XUZC50, XUZC50HP, XUZC50CR

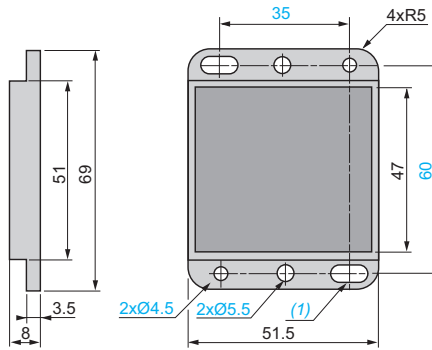

XUZC24

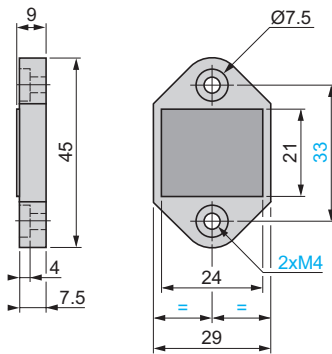

XUZC60S11

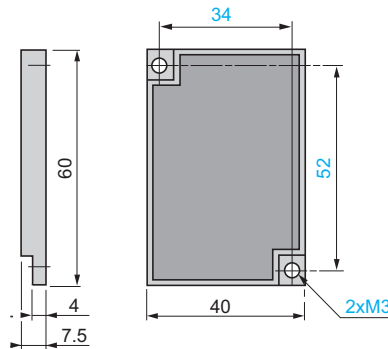

XUZC39

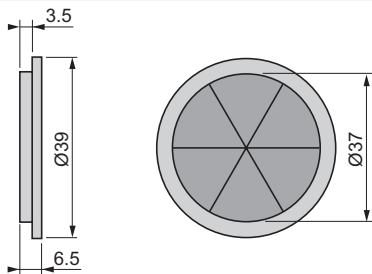

XUZC50HP, XUZC50CR

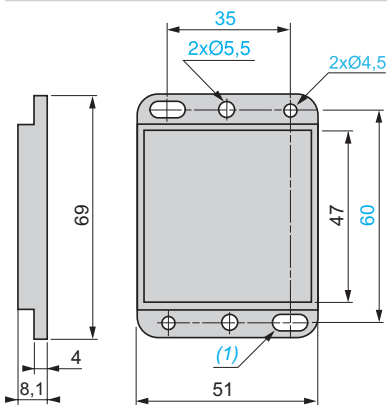

XUZCR0401HP

XUZCR0401CRHP

(1) 2 elongated holes Ø 4.5 x 8 for M4 screws

Note: All reflectors are IP 67 and IP 69K.

Photo-electric sensors

Cables for sensors

Pre-wired connectors

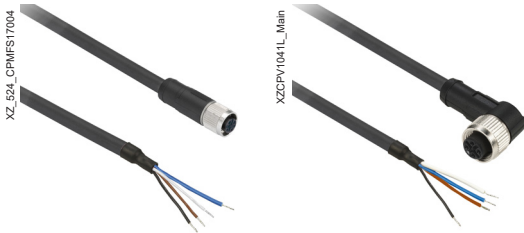

Pre-wired M8 connector, 4 conductors

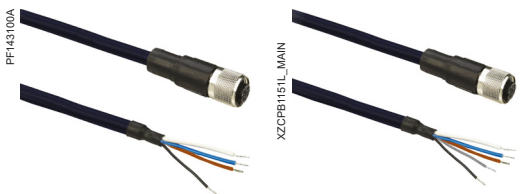

Pre-wired M12 connector, straight, 4 conductors (left) and 5 conductors (right)



Pre-wired M12 connector, elbowed, 4 conductors (left) and 5 conductors (right)

PVC cables with pre-wired connector

Description	Connector type	End fittings	Length (m)	For use with sensor	Reference	Weight kg
M8 connector						
Pre-wired M8 connectors	Female, straight	4-pin	2	XUM●●●●M8, XUT●●●●M8	XZCPV0941L2	0.090
			5		XZCPV0941L5	0.200
			10		XZCPV0941L10	0.380
	Female, elbowed	4-pin	2		XZCPV1041L2	0.090
			5		XZCPV1041L5	0.200
			10		XZCPV1041L10	0.380

M12 connector

Pre-wired M12 connectors	Female, straight	4-pin	2	XUM●●●●M12, XUM●●●●P015,	XZCPV1141L2	0.090
			5	XUN●●●●M12, XUB●●●●M12,	XZCPV1141L5	0.200
			10	XUT●●●●M12, XUVU04M3●●	XZCPV1141L10	0.380
	Female, elbowed	4-pin	2		XZCPV1241L2	0.090
			5		XZCPV1241L5	0.200
			10		XZCPV1241L10	0.380

PUR cables with pre-wired connector

Description	Connector type	End fittings	Length (m)	For use with sensor	Reference	Weight kg
M8 connector						
Pre-wired M8 connectors	Female, straight	4-pin	2	XUM●●●●M8, XUT●●●●M8	XZCP0941L2	0.080
			5		XZCP0941L5	0.180
			10		XZCP0941L10	0.360
	Female, elbowed	4-pin	2		XZCP1041L2	0.080
			5		XZCP1041L5	0.180
			10		XZCP1041L10	0.360

M12 connector

Pre-wired M12 connectors	Female, straight	4-pin	2	XUM●●●●M12, XUM●●●●P0●,	XZCP1141L2	0.090
			5	XUN●●●●M12, XUB●●●●M12,	XZCP1141L5	0.190
			10	XUK●●●●M12, XUVU04M3●●	XZCP1141L10	0.370
	Female, elbowed	4-pin	2		XZCP1241L2	0.090
			5		XZCP1241L5	0.190
			10		XZCP1241L10	0.370

M12 connector, shielded

Shielded pre-wired M12 connectors	Female, straight	4-pin	2	XUM●●●●M12, XUM●●●●P0●,	XZCPB1141L2	0.200
			5	XUN●●●●M12, XUB●●●●M12, XUK●●●●M12	XZCPB1141L5	0.350
			5-pin	XUKC●●●●	XZCPB1151L2	0.114
	Female, elbowed	4-pin	5		XZCPB1151L5	0.259
			2		XZCPB1251L2	0.113
			5		XZCPB1251L5	0.258



Jumper cables, M12-M12 connectors, 4-pin/4-pin



Shielded jumper cables, M12-M12 connectors, 5-pin/5-pin



Jumper cables, M12-M12 connectors, 4-pin/4-pin



Jumper cables, M8-M8 connectors, 3-pin/3-pin



Jumper cables, M8-M8 connectors, 3-pin/4-pin



Jumper cables, M8-M12 connectors, 3-pin/5-pin

PVC jumper cables

Description	Connector type		End fittings	Length (m)	For use with sensor	Reference	Weight kg
	Male	Female					
M12-M12 connectors							
PVC jumper cable XZ	M12, straight	M12, straight	4-pin/4-pin	1	XUM●●●●M12, XUM●●●●P015,	XZCRV1511041C1	0.070
				2	XUN●●●●M12, XUB●●●●M12,	XZCRV1511041C2	0.110
				5	XUT●●●●M12, XUVU04M3●●	XZCRV1511041C5	0.230
	M12, elbowed			1		XZCRV1512041C1	0.070
				2		XZCRV1512041C2	0.110
				5		XZCRV1512041C5	0.230

PUR jumper cables

Description	Connector type		End fittings	Length (m)	For use with sensor	Reference	Weight kg
	Male	Female					
Shielded, M12-M12 connectors							
PUR jumper cable XZ	M12, straight	M12, straight	5-pin/5-pin	2	XUCK●●●●	XZCRB151151C2	0.123
				5		XZCRB151151C5	0.267

M12-M12 connectors

PUR jumper cable XZ	M12, straight	M12, straight	4-pin/4-pin	1	XUVU04M3●●	XZCR1511041C1	0.065
				2		XZCR1511041C2	0.095
	M12, elbowed			1		XZCR1512041C1	0.065
				2		XZCR1512041C2	0.095

M8-M8 connectors

PUR jumper cable XZ	M8, straight	M8, straight	3-pin/3-pin	1	XUM●●●●M8, XUT●●●●M8	XZCR2705037R1	0.065
				2		XZCR2705037R2	0.090
				1		XZCR2706037R1	0.065
	M8, elbowed			2	XUM●●●●M8, XUT●●●●M8	XZCR2709037S2	0.090
				1		XZCR2609P2Y1	0.065
				2		XZCR2609P2Y2	0.095

M8-M12 connectors

PUR jumper cable XZ	M8, straight	M12, straight	3-pin/5-pin	1	XUM●●●●M8, XUT●●●●M8	XZCR2711037T1	0.065
				2		XZCR2711037T2	0.093
	M12, elbowed			1		XZCR2712037T1	0.065
				2		XZCR2712037T2	0.093



Connector type		Female, M8, straight	Female, M8, elbowed	Female, M12, straight	Female, M12, elbowed
Number of conductors		4			
References					
PVC cable	L = 2 m	XZCPV0941L2	XZCPV1041L2	XZCPV1141L2	XZCPV1241L2
	L = 5 m	XZCPV0941L5	XZCPV1041L5	XZCPV1141L5	XZCPV1241L5
	L = 10 m	XZCPV0941L10	XZCPV1041L10	XZCPV1141L10	XZCPV1241L10
Weight (kg)		0.090 (L = 2 m) 0.200 (L = 5 m) 0.380 (L = 10 m)			
Characteristics					
Certifications		cULus			
Connection type		Screw threaded (metal clamping ring)			
Cable material	Sheath	PVC			
	Conductor insulation	PP			
Degree of protection		IP65, IP67			
Ambient air temperature	Static cable	-25...+80 °C			
	Flexing cable	-5...+80 °C			
Conductor c.s.a		4 x 0.25 mm ²			
Cable diameter		4.6 mm			
Nominal voltage		60 V ~, 75 V ---		250 V ~, 300 V ---	
Nominal current		3 A			
Insulation resistance		> 10 ⁹ Ω			
Contact resistance		≤ 5 m Ω			

Connections

XZCPV0941L●,
XZCPV1041L●

XZCPV1141L●,
XZCPV1241L●

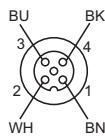
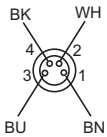

BN: Brown
WH: White
BU: Blue
BK: Black

Dimensions

XZCPV0941L●

XZCPV1041L●

XZCPV1141L●

XZCPV1241L●

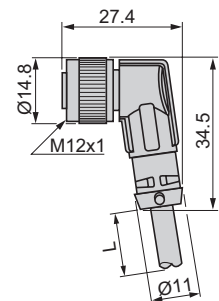
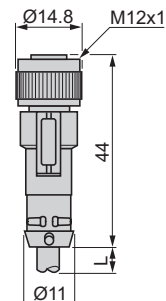
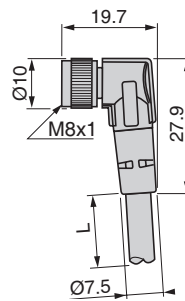
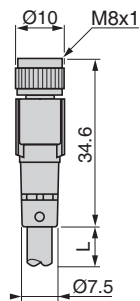

L = 2, 5 or 10 m

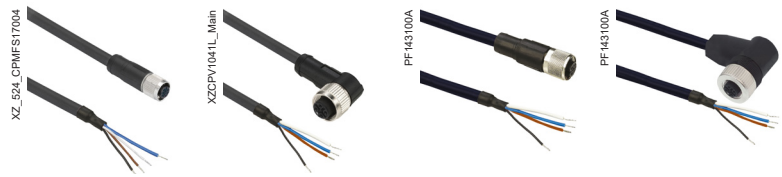

Connector type	Female, M8, straight	Female, M8, elbowed	Female, M12, straight	Female, M12, elbowed	
Number of conductors	4				
References					
PUR cable	L = 2 m	XZCP0941L2	XZCP1041L2	XZCP1141L2	XZCP1241L2
	L = 5 m	XZCP0941L5	XZCP1041L5	XZCP1141L5	XZCP1241L5
	L = 10 m	XZCP0941L10	XZCP1041L10	XZCP1141L10	XZCP1241L10
Weight (kg)	0.080 (L = 2 m) 0.180 (L = 5 m) 0.360 (L = 10 m)		0.090 (L = 2 m) 0.190 (L = 5 m) 0.370 (L = 10 m)		
Characteristics					
Certifications	cULus				
Connection type	Screw threaded (metal clamping ring)				
Cable material	Sheath	PUR			
	Conductor insulation	PP			
Degree of protection	IP65, IP67, IP69K				
Ambient air temperature	Static cable	-40...+80 °C			
	Flexing cable	-5...+80 °C			
Conductor c.s.a.	4 x 0.34 mm ²				
Cable diameter	5.2 mm				
Nominal voltage	60 V ~, 75 V ~		250 V ~, 300 V ~		
Nominal current	4 A				
Insulation resistance	> 10 ⁹ Ω				
Contact resistance	≤ 5 m Ω				

Connections

**XZCP0941L●,
XZCP1041L●**

**XZCP1141L●,
XZCP1241L●**

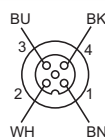
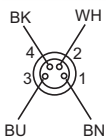

BN: Brown
WH: White
BU: Blue
BK: Black

Dimensions

XZCP0941L●

XZCP1041L●

XZCP1141L●

XZCP1241L●

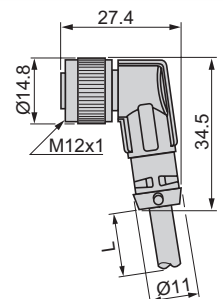
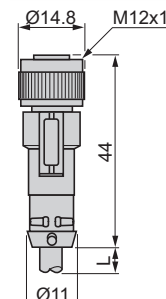
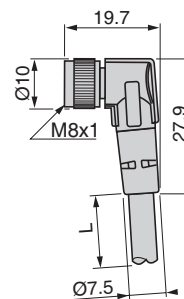
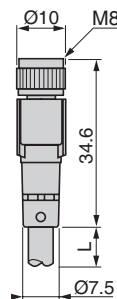

L = 2, 5 or 10 m

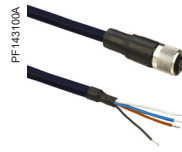

Connector type	Female, M12, straight	
Number of conductors	4	
References		
PUR cable	L = 2 m	XZCPB1141L2
	L = 5 m	XZCPB1141L5
Weight (kg)	0.200 (L = 2 m) 0.350 (L = 5 m)	

Characteristics		
Certifications	cULus	
Connection type	Screw threaded (metal clamping ring)	
Cable material	Sheath	PUR, shielded
	Conductor insulation	PP
Degree of protection	IP65, IP67	
Ambient air temperature	Static cable	-25...+80 °C
	Flexing cable	-5...+80 °C
Conductor c.s.a.	4 x 0.34 mm ²	
Cable diameter	5.9 mm	
Nominal voltage	250 V ~, 300 V ---	
Nominal current	4 A	
Insulation resistance	1 GΩ	
Contact resistance	5000 μOhm	

Connections

XZCPB1141L●

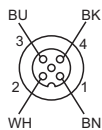

BN: Brown
WH: White
BU: Blue
BK: Black

Dimensions

XZCPB1141L●

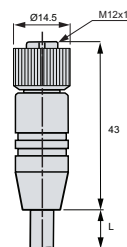

L = 2 or 5 m

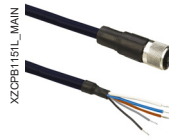

Connector type	Female, M12, straight	Female, M12, elbowed	
Number of conductors	5		
References			
PUR cable	L = 2 m	XZCPB1151L2	XZCPB1251L2
	L = 5 m	XZCPB1151L5	XZCPB1251L5
Weight (kg)	0.114 (L = 2 m) 0.259 (L = 5 m)	0.113 (L = 2 m) 0.258 (L = 5 m)	

Characteristics		
Certifications	cULus	
Connection type	Screw threaded (nickel clamping ring)	
Cable material	Sheath	PUR, shielded
	Conductor insulation	PP
Degree of protection	IP65, IP67, IP69K	
Ambient air temperature	Static cable	-40...+90 °C
	Flexing cable	-25...+80 °C
Conductor c.s.a.	5 x 0.34 mm ²	
Cable diameter	5.85 mm	
Nominal voltage	250 V ~, 60 V ---	
Nominal current	4 A	
Insulation resistance	> 10 ⁹ Ω	
Contact resistance	≤ 10 m Ω	

Connections
XZCPB1●51L●

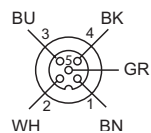

BN: Brown
WH: White
BU: Blue
BK: Black
GR: Grey

Dimensions
XZCPB1151L● XZCPB1251L●

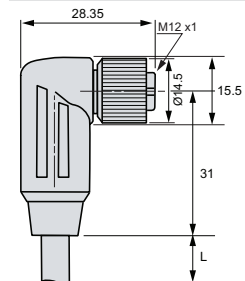
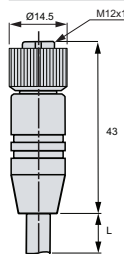

L = 2 or 5 m



Male connector type	M12, 4-pin, straight		
Female connector type	M12, 4-pin, straight	M12, 4-pin, elbowed	
Number of conductors	4		
References			
PVC cable	L = 1 m	XZCRV1511041C1	XZCRV1512041C1
	L = 2 m	XZCRV1511041C2	XZCRV1512041C2
	L = 5 m	XZCRV1511041C5	XZCRV1512041C5
Weight (kg)	0.070 (L = 1 m) 0.110 (L = 2 m) 0.230 (L = 5 m)		

Characteristics			
Certifications	cULus		
Connection type	Male and female	Screw threaded	
Cable material	Sheath	PVC	
	Conductor insulation	PP	
Degree of protection	IP65, IP67		
Ambient air temperature	Static cable	-25...+80 °C	
	Flexing cable	-5...+80 °C	
Conductor c.s.a	4 x 0.25 mm ²		
Cable diameter	4.6 mm		
Nominal voltage	250 V ~, 300 V ≍		
Nominal current	3 A		
Insulation resistance	> 10 ⁹ Ω		
Contact resistance	≤ 5 m Ω		

Dimensions

XZCRV1511041C1, XZCRV1511041C2, XZCRV1511041C5

XZCRV1512041C1, XZCRV1512041C2, XZCRV1512041C5

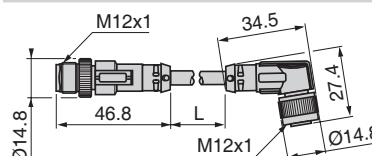
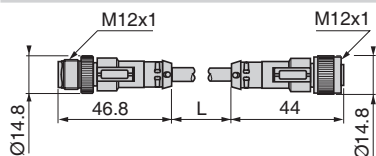

L = 2, 5 or 10 m

Connections

XZCRV1511041C●, XZCRV1512041C●

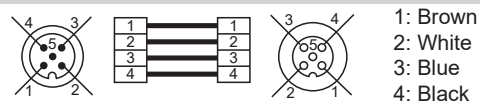

Photo-electric sensors

Cables for sensors, PUR

Jumper cables M12-M12

Shielded 5-pin/5-pin and unshielded 4-pin/4-pin



Male connector type	M12, 5-pin, straight	M12, 4-pin, straight	
Female connector type	M12, 5-pin, straight	M12, 4-pin, straight	M12, 4-pin, elbowed
Number of conductors	5	4	
References			
PUR cable	L = 1 m	–	XZCR1511041C1
	L = 2 m	XZCRB151151C2	XZCR1511041C2
	L = 5 m	XZCRB151151C5	–
Weight (kg)	0.123 (L = 2 m) 0.267 (L = 5 m)	0.065 (L = 1 m) 0.095 (L = 2 m)	

Characteristics			
Certifications		cULus	
Connection type	Male and female	Screw threaded	
Cable material	Sheath	PUR, shielded	PUR
	Conductor insulation	PP	–
Degree of protection		IP65, IP67, IP69K	
Ambient air temperature	Static cable	-40...+90 °C	-35...+90 °C
	Flexing cable	-25...+80 °C	-5...+90 °C
Conductor c.s.a		5 x 0.34 mm ²	4 x 0.34 mm ²
Cable diameter		5.85 mm ± 0.15 mm	5.2 mm
Nominal voltage		250 V ~, 60 V ---	250 V ~, 300 V ---
Nominal current		4 A	4 A
Insulation resistance		> 10 ⁹ Ω	≥ 10 ⁹ Ω
Contact resistance		≤ 10 m Ω	5000 m Ω

Dimensions

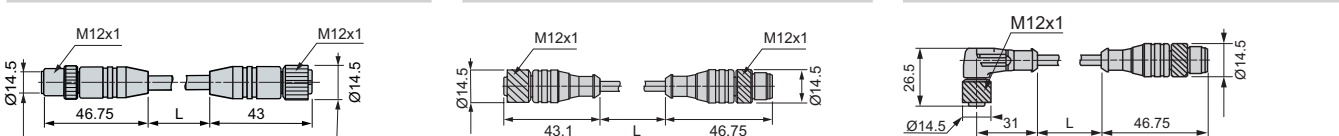

L = 2 or 5 m

L = 1 or 2 m

Connections

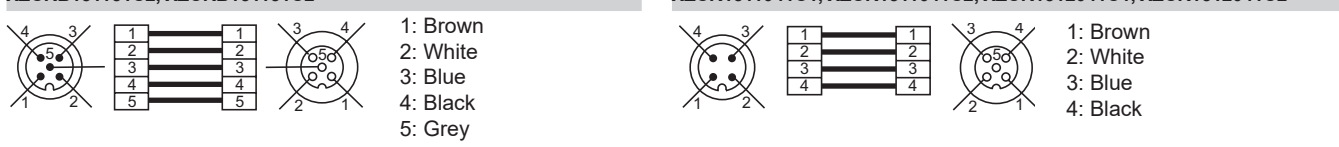

Photo-electric sensors

Cables for sensors, PUR
Jumper cables M8-M8,
3-pin/3-pin, 3-pin/4-pin, or 4-pin/4-pin



Male connector type	M8, 3-pin, straight			M8, 4-pin, straight
Female connector type	M8, 3-pin, straight	M8, 3-pin, elbowed	M8, 4-pin, straight	M8, 4-pin, straight
Number of conductors	3			

References					
PUR cable	L = 1 m	XZCR2705037R1	XZCR2706037R1	-	XZCR2609P2Y1
	L = 2 m	XZCR2705037R2	-	XZCR2709037S2	XZCR2609P2Y2
Weight (kg)	L = 1 m	0.065			
	L = 2 m	0.090			0.095

Characteristics			
Certifications		cULus	
Connection type	Male	Screw threaded and clip.	
	Female	Screw threaded. Metal clamping ring.	
Cable material	Sheath	PUR	
	Conductor insulation	PP	
Degree of protection		IP65, IP67, IP69K	
Ambient air temperature	Static cable	-35...+90 °C	
	Flexing cable	-5...+90 °C	
Conductor c.s.a.		3 x 0.34 mm ²	
Cable diameter		5.2 mm	
Nominal voltage		60 V ~, 45 V - -	30 V ~, 36 V - -
Nominal current		4 A	
Insulation resistance		> 10 ⁹ Ω	
Contact resistance		≤ 5 m Ω	

Dimensions

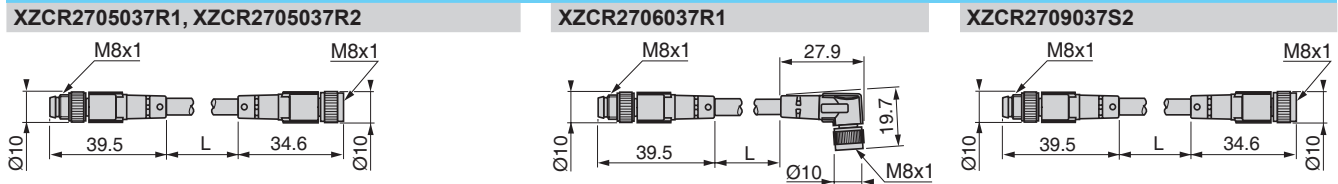

L = 1 or 2 m

Connections

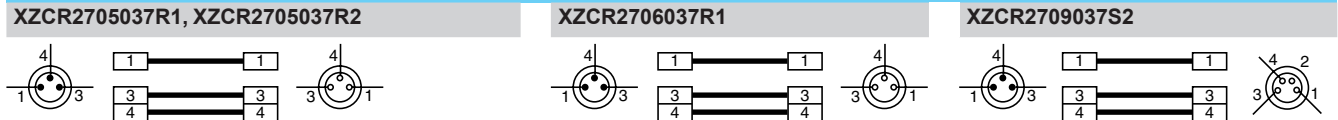



Male connector type	M8, 3-pin, straight			
Female connector type	M8, 4-pin, elbowed	M12, 5-pin, straight	M12, 5-pin, elbowed	
Number of conductors	3			
References				
PUR cable	L = 1 m	XZCR2710037S1	XZCR2711037T1	XZCR2712037T1
	L = 2 m	XZCR2710037S2	XZCR2711037T2	XZCR2712037T2
Weight (kg)	L = 1 m	0.065		
	L = 2 m	0.090	0.093	
Characteristics				
Certifications	cULus			
Connection type	Male	Screw threaded and clip.		
	Female	Screw threaded. Metal clamping ring.		
Cable material	Sheath	PUR		
	Conductor insulation	PP		
Degree of protection	IP65, IP67, IP69K			
Ambient air temperature	Static cable	-35...+90 °C		
	Flexing cable	-5...+90 °C		
Conductor c.s.a.	3 x 0.34 mm ²			
Cable diameter	5.2 mm			
Nominal voltage	60 V ~, 45 V ☰			
Nominal current	4 A			
Insulation resistance	> 10 ⁹ Ω			
Contact resistance	≤ 5 m Ω			

Dimensions

XZCR2710037S1, XZCR2710037S2

XZCR2711037T1, XZCR2711037T2

XZCR2712037T1, XZCR2712037T2

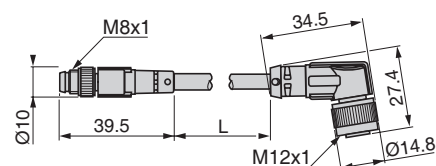
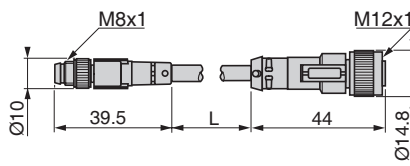
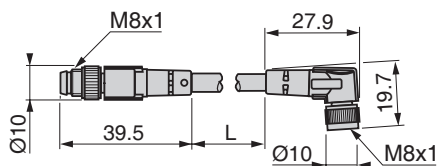

L = 1 or 2 m

Connections

XZCR2710037S1, XZCR2710037S2

XZCR2711037T1, XZCR2711037T2

XZCR2712037T1, XZCR2712037T2

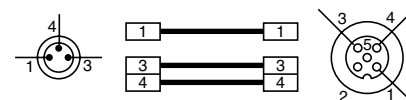
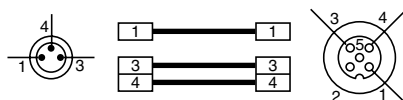

T					
TC SCTN011M11F	81	XUB5BPXNL2	27	XUM2APXBL03M12R	10
XG		XUB5BPXNM12	27	XUM2APXBM8	10
XGSZ12E4503	81	XUB5BPYNM12	27	XUM2APXBM8R	10
XGSZ12E4510	81	XUB6ANXNL2	26	XUM2APYBL03M12	10
XGSZ22E4503	81	XUB6ANXNM12	26	XUM2APYBL03M12R	10
XGSZ22E4510	81	XUB6ANXWL2	26	XUM2APYBM8	10
XU		XUB6ANXWM12	26	XUM2APYBM8R	10
XUB2AKXNL2T	23	XUB6APXNL2	26	XUM4ANXBL2	12
XUB2AKXNM12T	23	XUB6APXNM12	26	XUM4ANXBL03M8	12
XUB2AKXWL2T	23	XUB6APXWL2	26	XUM4ANXBL03M12	12
XUB2AKXWM12T	23	XUB6APXWM12	26	XUM4ANXBM8	12
XUB2ANXNL2	22	XUB6APYNM12	26	XUM4APXBL2	12
XUB2ANXNL2R	23	XUB6APYWM12	26	XUM4APXBL03M8	12
XUB2ANXNM12	22	XUB6BNXNL2	27	XUM4APXBL03M12	12
XUB2ANXNM12R	23	XUB6BNXNM12	27	XUM4APXBM8	12
XUB2ANXWL2	22	XUB6BNXWL2	27	XUM5ALAYL2	56
XUB2ANXWL2R	23	XUB6BNXWM12	27		66
XUB2ANXWM12	22	XUB6BPXNL2	27	XUM5ALAYM8	56
XUB2ANXWM12R	23	XUB6BPXNM12	27		66
XUB2APXNL2	22	XUB6BPXWL2	27	XUM5ALAYP015	56
XUB2APXNL2R	23	XUB6BPXWM12	27		66
XUB2APXNM12	22	XUB6BPYNM12	27	XUM5ANXBL2	12
XUB2APXNM12R	23	XUB6BPYWM12	27	XUM5ANXBL03M8	12
XUB2APXWL2	22	XUB9ANXNL2	28	XUM5ANXBL03M12	12
XUB2APXWL2R	23	XUB9ANXNM12	28	XUM5ANXBM8	12
XUB2APXWM12	22	XUB9ANXWL2	28	XUM5APXBL2	12
XUB2APXWM12R	23	XUB9ANXWM12	28	XUM5APXBM8	12
XUB2APYNM12	22	XUB9APXNL2	28	XUM5APYBL03M12	12
XUB2APYNM12R	23	XUB9APXNM12	28	XUM5APYBM8	12
XUB2APYWL2	22	XUB9APXWL2	28	XUM6ANXBL2	12
XUB2APYWM12	22	XUB9APXWM12	28	XUM6ANXBL03M8	12
XUB2APYWM12R	23	XUB9APYNM12	28	XUM6ANXBL03M12	12
XUB2BKXNL2T	25	XUB9APYWM12	28	XUM6ANXBM8	12
XUB2BKXNM12T	25	XUB9BNXNL2	29	XUM6APXBL2	12
XUB2BKXWL2T	25	XUB9BNXNM12	29	XUM6APXBL03M8	12
XUB2BKXWM12T	25	XUB9BNXWL2	29	XUM6APXBL03M12	12
XUB2BNXNL2	24	XUB9BNXWM12	29	XUM6APXBM8	12
XUB2BNXNL2R	25	XUB9BPXNL2	29	XUM6APYBL03M12	12
XUB2BNXNM12	24	XUB9BPXNM12	29	XUM6APYBM8	12
XUB2BNXNM12R	25	XUB9BPXWL2	29	XUM7ABPXL2	60
XUB2BNXWL2	24	XUB9BPXWM12	29		74
XUB2BNXWL2R	25	XUB9BPYNM12	29	XUM7ABPXM8	60
XUB2BNXWM12	24	XUB9BPYWM12	29		74
XUB2BNXWM12R	25	XUK8ABPXM12	60	XUM8ABAYM8	60
XUB2BPXNL2	24		74	XUM8ABAYP015	60
XUB2BPXNL2R	25	XUKCBLAYM12	72		74
XUB2BPXNM12	24	XUKCBSAYM12	72	XUM8ALAYL2	66
XUB2BPXNM12R	25	XUM2AKXBL2T	10	XUM8ALAYM8	66
XUB2BPXWL2	24	XUM2AKXBL03M8T	10	XUM8ALAYP015	66
XUB2BPXWL2R	25	XUM2AKXBL03M12T	10	XUM8ANXBL2	11
XUB2BPXWM12	24	XUM2AKXBM8T	10	XUM8ANXBM8	11
XUB2BPXWM12R	25	XUM2ANXBL2	10	XUM8APXBL2	11
XUB2BPYNM12	24	XUM2ANXBL2R	10	XUM8APXBM8	11
XUB2BPYNM12R	25	XUM2ANXBL03M8	10	XUM8PLPXM8	66
XUB2BPYWM12	24	XUM2ANXBL03M8R	10	XUM9ALAYL2	66
XUB2BPYWM12R	25	XUM2ANXBL03M12	10	XUM9ALAYM8	66
XUB5ANXNL2	26	XUM2ANXBL03M12R	10	XUM9ALAYP015	66
XUB5ANXNM12	26	XUM2ANXBM8	10	XUM9ANXBL2	11
XUB5APXNL2	26	XUM2ANXBM8R	10	XUM9ANXBL03M8	11
XUB5APXNM12	26	XUM2APXBL2	10	XUM9ANXBL03M12	11
XUB5APYNM12	26	XUM2APXBL2R	10	XUM9ANXBM8	11
XUB5BNXNL2	27	XUM2APXBL03M8	10	XUM9APXBL2	11
XUB5BNXNM12	27	XUM2APXBL03M8R	10	XUM9APXBL03M8	11
		XUM2APXBL03M12	10	XUM9APXBL03M12	11
				XUM9APXBM8	11
				XUM9APYBL03M12	11
				XUM9PLPXM8	66
				XUMpPLPXM8	67
				XUMRACAYM8	56
					72
				XUMRAGAYM8	56
				XUMRAGAYP015	56
				XUMRAWAYM8	56
				XUMRAWAYP015	56
				XUMRPGAYM8	56
					57
				XUMTARAYL2	74
				XUMTARAYM8	74
				XUMTARAYP015	74
				XUMTPRPXM8	74
					75
				XUN2AKXNL2T	42
				XUN2AKXNM12T	42
				XUN2ANXNL2	42
				XUN2ANXNL2R	42
				XUN2ANXNM12	42
				XUN2ANXNM12R	42
				XUN2APXNL2	42
				XUN2APXNL2R	42
				XUN2APXNM12	42
				XUN2APXNM12R	42
				XUN2APYNM12	42
				XUN2APYNM12R	42
				XUN5ANXNL2	43
				XUN5ANXNM12	43
				XUN5APXNL2	43
				XUN5APXNM12	43
				XUN5APYNM12	43
				XUN6ANXNL2	43
				XUN6ANXNM12	43
				XUN6APXNL2	43
				XUN6APXNM12	43
				XUN6APYNM12	43
				XUN9ANXNL2	44
				XUN9ANXNM12	44
				XUN9APXNL2	44
				XUN9APXNM12	44
				XUN9APYNM12	44
				XUT7ABPXL2	60
					74
				XUT7ABPXP02	60
					74
				XUT8ABAYL2	60
					74
				XUT8ABAYP02	60
					74
				XUT8ALAYL2	66
				XUT8ALAYP02	66
				XUT9ALPXL2	66
				XUT9ALPXP02	66
				XUZA50	84
				XUZA51S	84
				XUZA118	84
				XUZA218	84
				XUZARK	84
				XUZARM	84
				XUZARS	84
				XUZASB001	84
				XUZASB002	84
				XUZASB003	84
				XUZASK001	84
				XUZASM02	84
				XUZASM03	84
				XUZASM04	84
				XUZASM05	13
				XUZASN001	84
				XUZASN002	84
				XUZASS	84
				XUZASW001	84
				XUZASW002	84
				XUZC24	88
				XUZC39	88
				XUZC50	88
				XUZC50CR	88
				XUZC50HP	88
				XUZC50HP, XUZC50CR	89
				XUZC60S11	88
				XUZC100	88
				XUZCR0401CRHP	88
					89
				XUZCR0401HP	88
					89
				XUZDHM05	13
				XUZDHM10	13
				XUZDHM20	13
				XUZDRM05	13
				XUZDRM10	13
				XUZDRM20	13
				XUZDVM05	13
				XUZDVM10	13
				XUZDVM20	13
				XZ	
				XZCP0941L2	90
					93
				XZCP0941L5	90
					93
				XZCP0941L10	90
					93
				XZCP1041L2	90
					93
				XZCP1041L5	90
					93
				XZCP1041L10	90
					93
				XZCP1141L2	90
					93
				XZCP1141L5	90
					93
				XZCP1141L10	90
					93
				XZCP1241L2	90
					93
				XZCP1241L5	90
					93
				XZCP1241L10	90
					93
				XZCPB1141L2	90
					94
				XZCPB1141L5	90
					94
				XZCPB1151L2	90
					95
				XZCPB1151L5	90
					95

XZ (continued)		XZCRV1511041C1	91
XZCPB1251L2	90		96
	95	XZCRV1511041C2	91
XZCPB1251L5	90		96
	95	XZCRV1511041C5	91
XZCPK75CL2	81		96
XZCPK75CL5	81	XZCRV1512041C1	91
XZCPK75DL2	81		96
XZCPK75DL5	81	XZCRV1512041C2	91
XZCPV0941L2	90		96
	92	XZCRV1512041C5	91
XZCPV0941L5	90		96
	92	XZIOM8AM12EY	81
XZCPV0941L10	90	XZIOM8AM12PY	81
	92		
XZCPV1041L2	90		
	92		
XZCPV1041L5	90		
	92		
XZCPV1041L10	90		
	92		
XZCPV1141L2	90		
	92		
XZCPV1141L5	90		
	92		
XZCPV1141L10	90		
	92		
XZCPV1241L2	90		
	92		
XZCPV1241L5	90		
	92		
XZCPV1241L10	90		
	92		
XZCR25K25DL2	81		
XZCR25K25DL5	81		
XZCR26K26CL2	81		
XZCR26K26CL5	81		
XZCR2609P2Y1	91		
	98		
XZCR2609P2Y2	91		
	98		
XZCR1511041C1	91		
	97		
XZCR1511041C2	91		
	97		
XZCR1512041C1	91		
	97		
XZCR1512041C2	91		
	97		
XZCR2705037R1	91		
	98		
XZCR2705037R2	91		
	98		
XZCR2706037R1	91		
	98		
XZCR2709037S2	91		
	98		
XZCR2710037S1	99		
XZCR2710037S2	99		
XZCR2711037T1	91		
	99		
XZCR2711037T2	91		
	99		
XZCR2712037T1	91		
	99		
XZCR2712037T2	91		
	99		
XZCRB151151C2	91		
	97		
XZCRB151151C5	91		
	97		

www.telemecaniquesensors.com

The information provided in this catalogue contains description of products sold by TMSS France, its subsidiaries and other affiliated companies ('Offer') with technical specifications and technical characteristics of the performance of the corresponding Offer.

The content of this document is subject to revision at any time without notice due to continued progress in methodology, design and manufacturing.

To the extent permitted by applicable law, no responsibility or liability is assumed by TMSS France, its subsidiaries and other affiliated companies for any type of damage arising out of or in connexion with (a) informational content of this catalogue not conforming with or exceeding the technical specifications, or (b) any error contained in this catalogue, or (c) any use, decision, act or omission made or taken on the basis of or in reliance on any information contained or referred to in this catalogue.

NEITHER TMSS FRANCE, ITS SUBSIDIARIES, NOR ITS OTHER AFFILIATES, AS THE CASE MAYBE, MAKE NO WARRANTY OR REPRESENTATION OF ANY KIND, WHETHER EXPRESS OR IMPLIED, AS TO WHETHER THIS CATALOGUE OR ANY INFORMATION CONTAINED THEREIN SUCH AS PRODUCTS WILL MEET REQUIREMENTS, EXPECTATIONS OR PURPOSE OF ANY PERSON MAKING USE THEREOF.

Telemecanique™ Sensors is a trademark of Schneider Electric Industries SAS used under license by TMSS France. Any other brands or trademarks referred to in this catalogue are property of TMSS France or, as the case may be, of its subsidiaries or other affiliated companies. All other brands are trademarks of their respective owners. This catalogue and its content are protected under applicable copyright laws and provided for informative use only.

No part of this catalogue may be reproduced or transmitted in any form or by any means (electronic, mechanical, photocopying, recording, or otherwise), for any purpose, without the prior written permission of TMSS France. Copyright, intellectual, and all other proprietary rights in the content of this catalogue (including but not limited to audio, video, text, and photographs) rests with TMSS France, its subsidiaries, and other affiliated companies or its licensors. All rights in such content not expressly granted herein are reserved. No rights of any kind are licensed or assigned or shall otherwise pass to persons accessing this information.

As standards, specifications and design change from time to time, please ask for confirmation of the information given in this publication.

©2025, TMSS France, All Rights Reserved.

TMSS France SAS

Share capital: 366 931 214 €
Tour Eqho, 2 avenue Gambetta
92400 Courbevoie – France
908 125 255 RCS Nanterre

January 2025 - V2.0

TESEBRO000068EN